

FLAME DETECTOR FOR GAS TYPE RE3



DESCRIPTION

The RE3 control is suitable to verify the presence of flame on gas burners. In fact it can use either a UV phototube or an electrode to exploit the flame rectification effect (ionization).

FEATURES

- in accordance with EN 60730;
- electrical service life at max. declared loading > 250.000 operations;
- compact and easy installation;
- connecting socket with screws or fast-on terminals (types A, B, N and T);
- signalization with LEDs of different colour: green (POWER) and red (FLAME).

MAIN APPLICATIONS

The RE3 flame detector is mainly used for industrial applications and for the installation of semiautomatic ignition and control systems, when it is necessary to control simultaneously and sequentially several burners.

The presence of LEDs to signalise the operation also permits the use of RE3 control simply as flame detector.

OPERATION

Supply is signalled by the turning on of the green coloured LED (POWER) fitted on the front of the plastic enclosure. A second LED, red coloured, placed next to the first one, turns on when the flame detection has occurred. This event corresponds to the switching on of the independent contacts available in output.

OVERALL DIMENSIONS

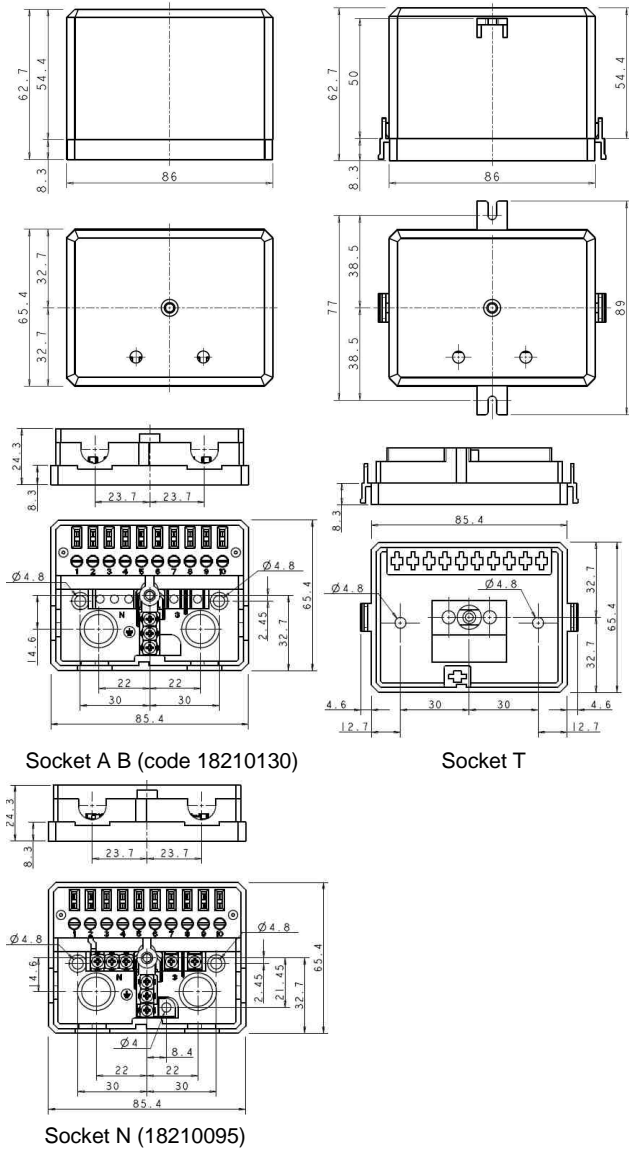

Fig.1

This control can use the connecting sockets with screw terminals mod. A B, N or socket mod. T. for fast - on terminals, which couples with lateral bolted enclosure.

ACCESSORIES

The users' different requirements regarding flame detection for gas systems, can be met by using the following probes of our production:

- **UV1** standard phototube (Fig.2);
- **UV1/H** high sensitivity phototube:
 - Case: nylon
 - Case diameter: mm 22
 - Case length: mm 85
 - Cable length: mm 600 (standard)
- **UV2/N** (Fig.3):
 - Case: nylon
 - Case diameter: mm 17
 - Case length: mm 76
 - Cable length: mm 600 (standard)

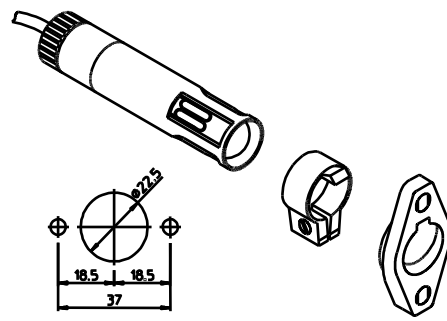

Fig.2

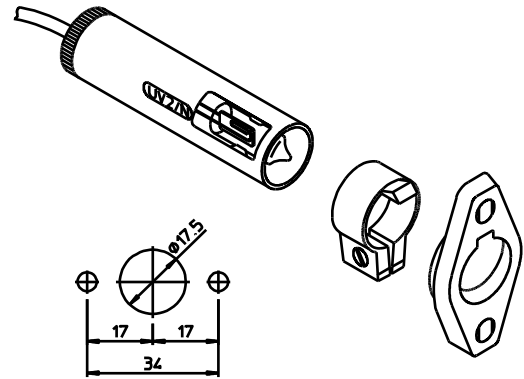

Fig.3

As regards the phototube life, we suggest to replace it after 10.000 hours to avoid the danger of a "flame on" signal also after the flame has been extinguished, which is likely to happen when the tube gets too old.

DETECTION ELECTRODE

The detection electrode we produce can be supplied in different shapes and dimensions (see Fig.4).

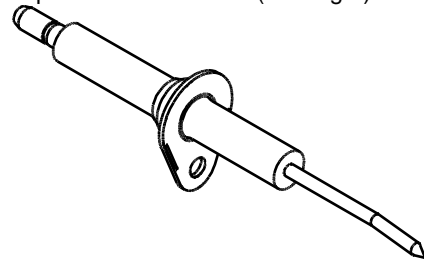

Fig.4

TECHNICAL DATA

- Supply: 220-230V-50/60Hz
- on request: 240V-50/60Hz
- 110-120V-50/60Hz
- Operating temperature: 0 ÷ 60°C
- Humidity: 95% max. at 40°C
- Case Protection Degree: IP40
- Power consumption in running: 3 VA
- Contact rating: 5A 250 V AC (cosφ = 1.0)
- 3A 250 V AC (cosφ = 0.4)
- 5A 30 V DC
- External Fuse (F): 50 mA T
- Minimum ionization current: 0,5μA
- Recommended ionization current:
 - with UV tube: > 15μA
 - with electrode: > 5μA
- Reaction time: < 1s

Weight:

| | |
|----------------|-------|
| with AB socket | 280 g |
| with B socket | 300 g |
| with T socket | 250 g |
| with N socket | 290 g |

CONSTRUCTION

The plastic material made enclosure protects the control from possible damages depending on crashes, openings, dust deposit, contact with outside ambient.

Two LEDs of different colour, GREEN for power on and RED for flame on, fitted on the upper side of the enclosure, permit an immediate identification of the state of burner and control; a version without signalling LEDs is also available.

DIRECTIONS FOR INSTALLATION

- Connect and disconnect the control only with supply off.
- The control can be assembled in every position.
- Avoid exposure to dripping water.
- Ventilation with the lowest temperature ensures the longest life of the control.
- Make sure that you are using the correct type and code before installing or replacing the control.

ELECTRICAL INSTALLATION

- Every contact must be protected with a fuse of the fast blow type suitable to the loads connected;
- **Before starting the control, check cables and connections carefully (see Fig.5). Wrong connections can damage the control and compromise the safety of the application;**
- Avoid placing the detection cable close to power or ignition cables;
- Use a detection cable as short as possible (max. recommended length <5m);
- A suitable degree of protection must be guaranteed;
- The relevant electrical safety standards must be respected.

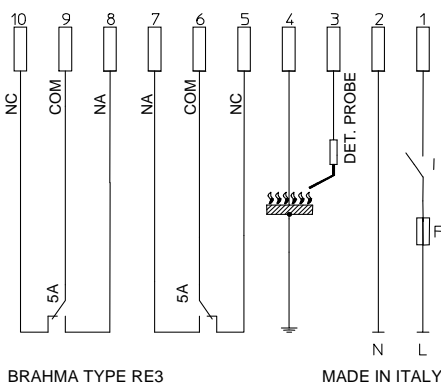
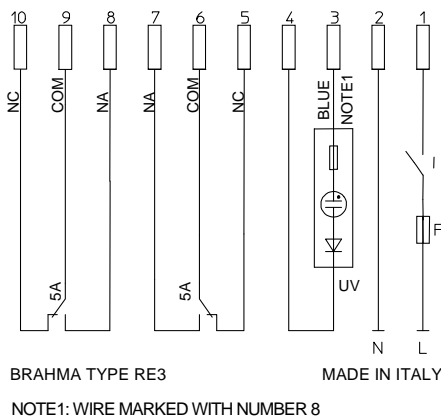

Fig.5

CHECKING AT START

Always check the control before the first start and also after a long period of system off. Before any ignition attempt make sure that the combustion chamber is free from gas. Then check that the level of the flame signal is sufficient (see Fig.6a and 6b for the measuring).

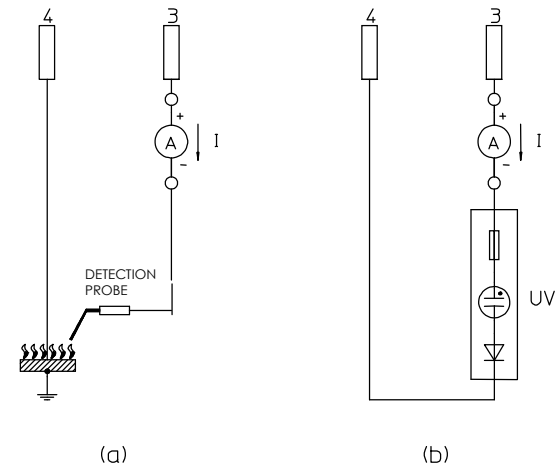
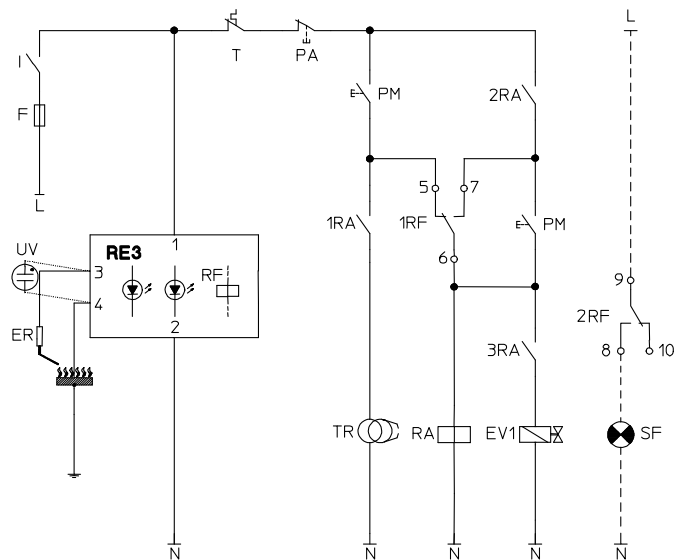

Fig.6

Fig.7 shows the diagram suitable to the installation of a semiautomatic system for gas burners. For the flame detection, both an ionization electrode or a phototube can be used.

Acting on the manual start button PM (with two contacts normally open) supply is given to the TR ignition transformer and the EV 1 gas valve; the manual pressure on the button must be kept until the flame is built and stable.

APPLICATION EXAMPLES



By releasing the button PM, the ignition transformer is turned off and the operation continues until one of the following situations occurs:

- action on the manual stop button PA;
- intervention of the thermostat T;
- flame failure.

In any situation, the operation can be reset only by manual intervention on start button PM.

In the same picture is also represented a duty example of the second available contact, to detect the flame in distance.

Fig.8 represents two connection diagrams for using the RE3 flame detector with the control box for automatic gas burners, model CM391 belonging to the EUROBOX series (see the relevant leaflet).

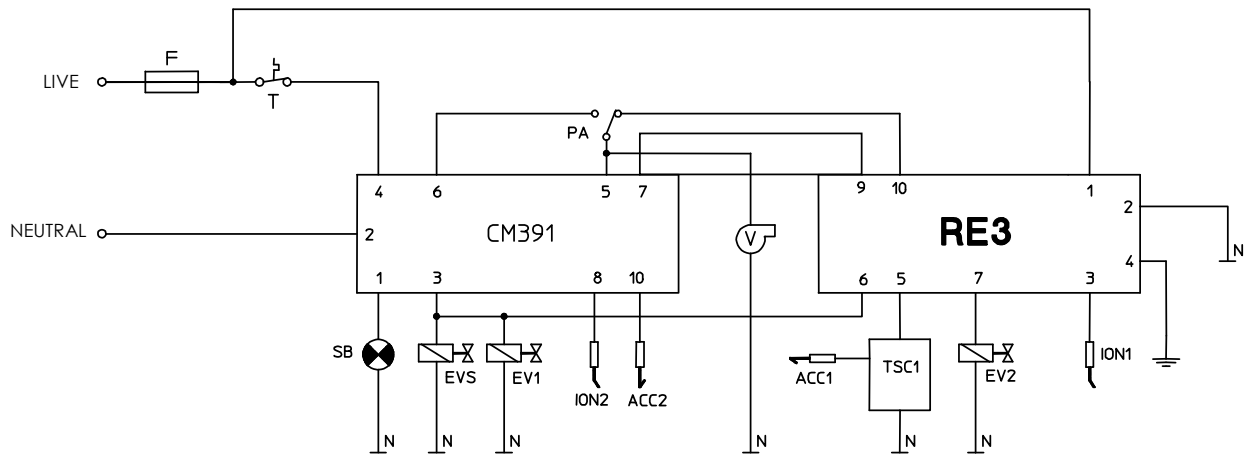
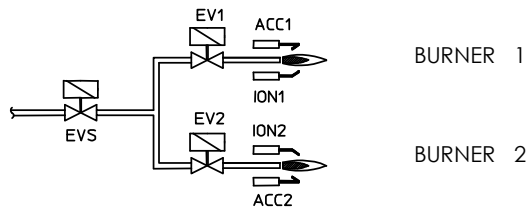

(a)

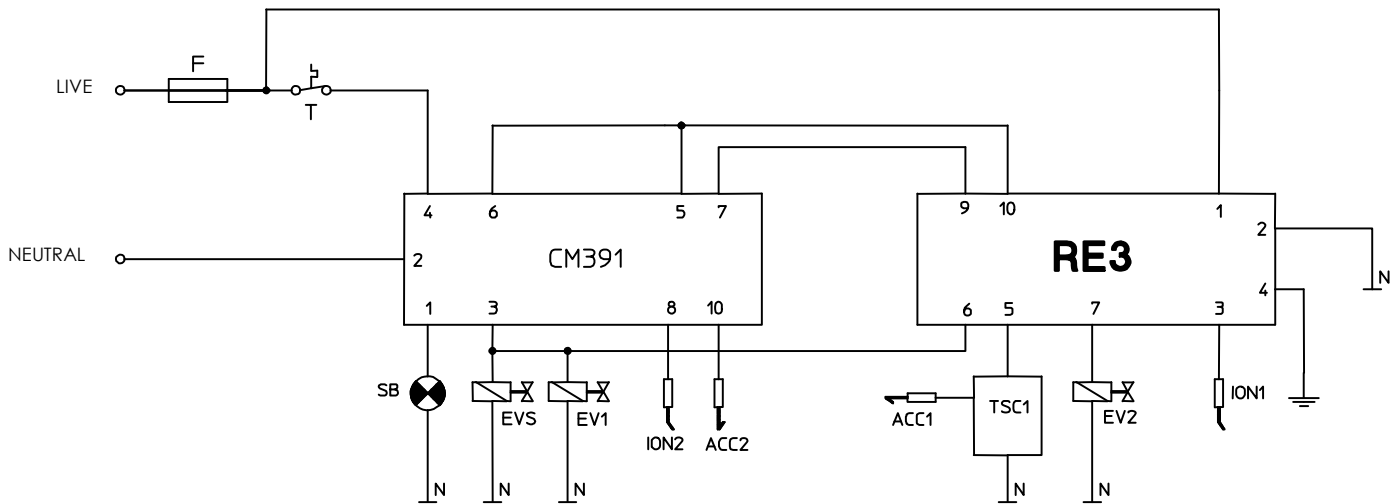

(b)

Fig.8

The diagram in Fig.8a differs from the one in Fig.8b for the presence of fan control and air pressure switch. This connection permits the ignition of two burners in sequence, with cross checking of the "flame on" state. A contact of the internal relay of RE3 is used to check the efficiency of the detector to prevent the beginning of the ignition cycle if the detector doesn't operate correctly.

The ignition of burner 2 occurs only after the ignition of burner 1 and, as the flame detection is cross - checked between CM391 and RE3, the turning off of one burner causes also the immediate turning off of the other one.



NOTES ABOUT PRODUCT DISPOSAL The device contains electronic components and cannot therefore be disposed of as normal household waste. For the disposal procedure, please refer to the local rules in force for special waste.

ATTENTION-> Company Brahma S.p.A. declines any responsibility for any damage resulting from the Customer's interfering with the device.

BRAHMA S.p.A.

Via del Pontiere, 31
 37045 Legnago (VR)
 Tel. +39 0442 635211 - Telefax +39 0442 25683
 http://www.brahma.it
 E-mail : brahma@brahma.it

22/06/2017 Subject to amendments without notice