

## AT5/TR CONTROL BOX

**CONTROL BOX FOR ATMOSPHERIC GAS BURNERS WITH POWER UP TO 350KW WITH INBUILT IGNITION TRANSFORMER**

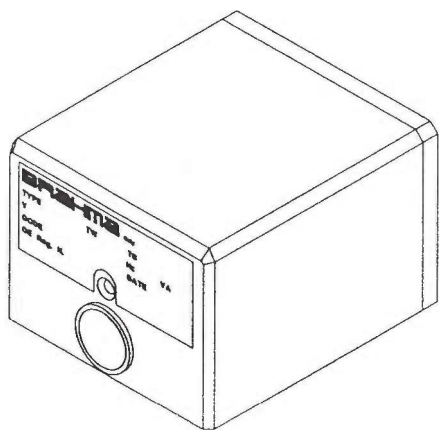

### DESCRIPTION

The AT5/TR control box is suitable for atmospheric gas burners for civil and industrial applications for power up to 350KW.

According to TÜV Bayern, Monaco, the control is in compliance with the German regulation DIN 4788, part 3, for power up to 350KW. It also obtained the DIN-DVGW 91.02fBN approval, now expired and not renewable.

The "Laboratorio di Macchine e Termotecnica del Centro Studi ed Esperienze" in Roma - Capannelle tested the AT5/TR control for power up to 350KW, which obtained the certification no. 3704/10-77/8 and the approval of the Ministry of the Interior for fire prevention (circulars no. 68 and no. 42).

### TECHNICAL DATA

Supply voltage (1):	220V (-20% +10%) 50Hz (±5%)
Operating temperature range:	-10°C +60°C
Protection degree:	IP40
Starting power consumption:	15 VA
Operating power consumption:	7.5 VA
Contact rating:	I max.
- valves:	2 A
- alarm:	1 A
- thermostat:	6 A
Times:	
- waiting time (TW):	15 s approx.
- safety time (TS):	10 s
- dropout time on running flame failure:	< 1 s
- delay between EVP and EV2:	15 s approx.
Flame control:	
- min. ionization current:	0.5 µA
- recommended ionization current:	>5 µA
- min. insulation resistance between electrode, cable and earth:	> 50 MΩ
Ignition transformer:	
- ignition voltage:	8 KV
- secondary voltage:	6 mA actual
- consumption:	7 VA
- spark energy:	45 mJ
Weight including socket:	515 g

(1) Versions with different supply voltage are available.

## CONSTRUCTION

The components of the control are mounted on a pressed frame made of thermohardening material, with high dielectric resistance. The plastic casing protects the device from possible damages resulting from crashes, incautious opening, dust and contact with the external environment. Flexible unipolar conductors of different sizes connect the components of the control, except for the flame detection circuit.

## OVERALL DIMENSIONS

The overall dimensions of the control box are shown in Fig.1.

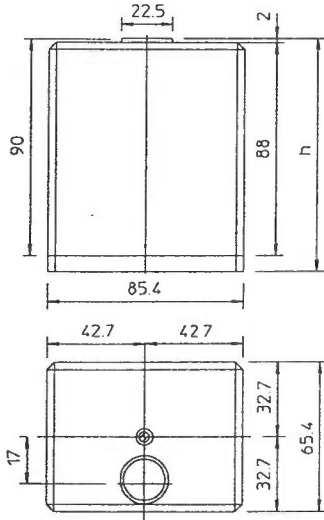

h: the dimensions depend on the type of socket : 99 with type F  
98.3 with type NF

Fig.1

## CONNECTION

As regards the interconnection system of this control, several solutions are possible and different types of connecting sockets can be employed (see Fig.4 and Fig.5). Socket NF differs from socket F for its dimensions and the higher number of terminals connecting neutral and earth.

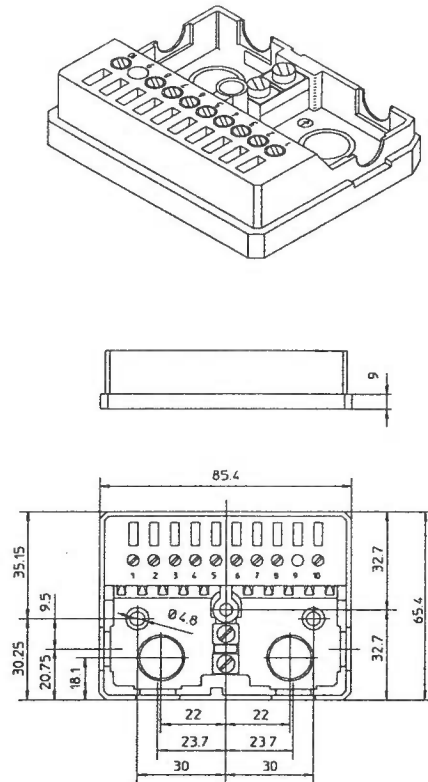

Socket F  
Fig.4

## ACCESSORIES

The control incorporates an inbuilt reset button and a luminous lockout signal. The device can be fitted with the pilot burner shown in Fig.2.

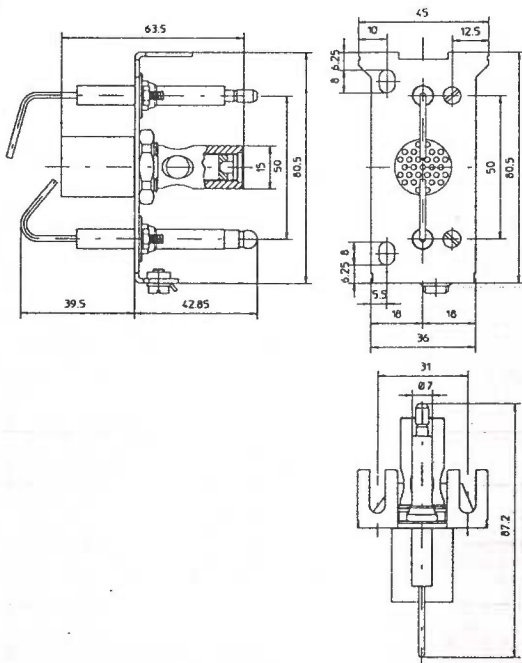
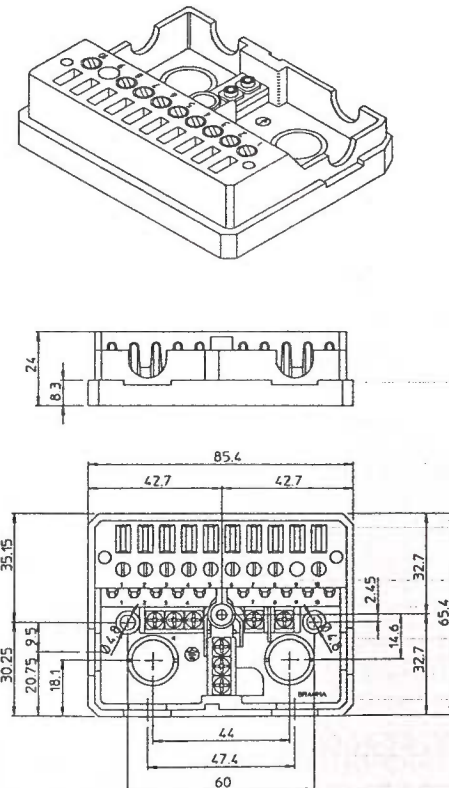

Fig.2



Socket NF  
Fig.5

The control housing is prearranged for the use of cable holders and core hitches fitted on the lateral sides; these accessories can be supplied on request too.

## DIRECTIONS FOR INSTALLATION

- Automatic controls are safety devices and must not be opened. The manufacturer's responsibility and guarantee are invalidated if the control is incautiously opened.
- For safety reasons a regulation shutdown must occur every 24 hours.
- The device can be mounted in any position.
- **Live and neutral** should be connected correctly; a mistake could cause a dangerous situation.
- The earth terminal of the control, the metal frame of the burner, the earth of the ignition transformer and the earth of the electric system must be well connected.
- Make sure that the discharge of the ignition transformer does not hit the detection electrode.
- The connecting cable of the detection electrode must not be longer than 20 meters.
- Avoid putting the detection cable close to power or ignition cables.
- Use a heat resistant detection electrode and cable, well insulated to the ground and protected from humidity or water in general.
- Always check the control before the first start and also after any replacement or after a long period of non-operation of the system. In particular make sure that:
  - the connections are corresponding to the scheme below;
  - the intervention of limiters or safety devices causes a safety shutdown according to the application;
  - the level of the flame signal is high enough.
- A short circuit between detection electrode and burner casing does not cause any flame simulation.
- In running state, a leakage of the detection electrode to earth stops the fuel supply and causes the repetition of the whole ignition cycle.

In case of live-neutral network with unearthed neutral or live-live network (with unearthed centre of the star), the control does not work properly, therefore it is necessary to connect an R-C dual pole between neutral and earth. The presence of leakage between live and earth may reduce the voltage on the detection probe until it causes the device to lock out. In the presence of this kind of network it is advisable to use our step-up transformer type AR1.

## THERMAL TIMERS

The safety time is obtained by means of a compensated thermal timer. The fixed value of 220V/20° does not vary of more than 25% with voltage (-20% +10%) and temperature (-10°C +60°C) variations. The waiting time is given by a thermal timer too. This timer, combined with the corresponding electronic circuit, grants a waiting time of about 15 seconds even in case of voltage variations (-20% +10%), ambient temperature variations (-10°C +60°C), interruption of the current supply for any time or frequent and repeated starts of the unit.

## OPERATING CYCLE

At every start the control unit proceeds to the self-checking of its own components. During the waiting time the internal circuit makes a test of the flame signal amplifier. A parasitic flame signal or a fault in the amplifier leading to the same condition prevent the device from starting. At the elapsing of the waiting time the gas valve and the ignition device are supplied, thus starting the safety time. If a flame signal is detected during the safety time, the ignition device is inhibited and the EV1 valve is energized. About 15 seconds after the flame detection has occurred, the EV2 valve is energized too. If the control does not detect any flame signal at the end of the safety time, it proceeds to lockout, the EVP valve is closed, the ignition transformer is inhibited and the lockout signal is supplied. The following diagram is useful for a better understanding of the whole operating cycle.

## ELECTRIC SCHEME

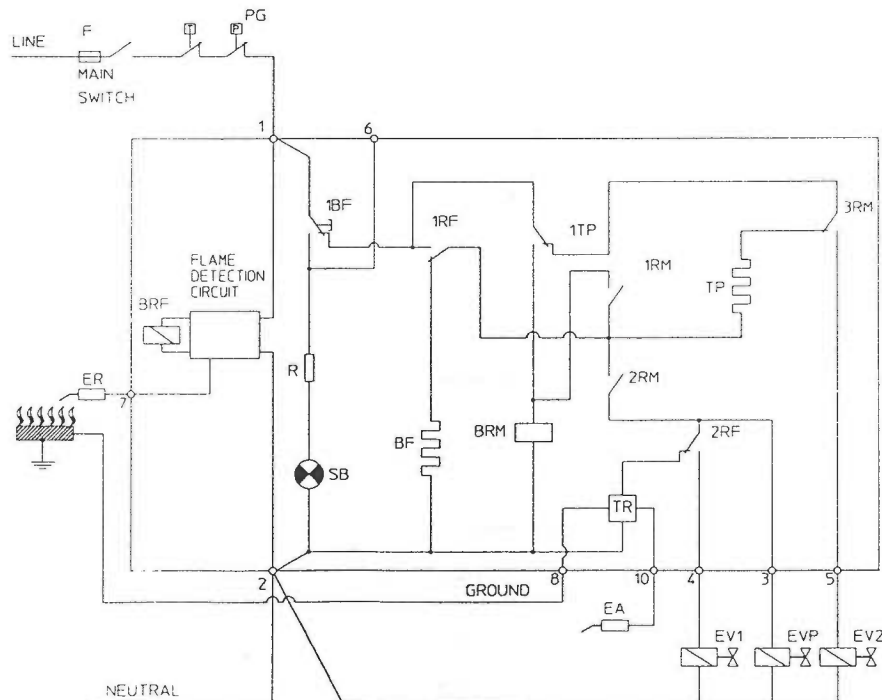

BRM	Operation relay	EV1	First main valve
BRF	Flame detection relay	EV2	Second main valve
BF	Safety time thermal	EVP	Pilot valve
EA	Ignition electrode	SB	Lockout signal
ER	Detection electrode	TP	Waiting time thermal

### Abnormal operation

- Parasitic flame signal:

The presence of a parasitic flame signal at start or during the waiting time prevents the control box from continuing the operating cycle.

Flame failure during operation causes the repetition of the whole ignition cycle.

### RESET OF THE CONTROL

To reset the control from lockout, act on the reset button after waiting for the restoration of the lockout thermal, which normally takes about 20 seconds.

### CONNECTION DIAGRAM

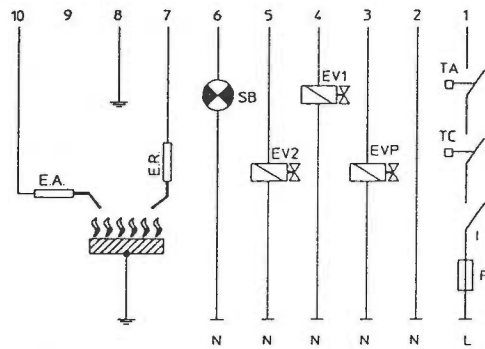

### OPERATING CYCLE

