

VK41..VK81..A/B/C/D

GAS CONTROLS FOR COMBINED VALVE AND IGNITION SYSTEM

INSTRUCTION SHEET



SPECIFICATIONS

Model

VK41.0: 220 ... 240 Vrac
 VK41.5: 220 ... 240 Vrac without pilot burner connection
 VK81.0: 24 Vrac
 VK81.5: 24 Vrac without pilot burner connection

Suffix A: fast opening with pressure regulator
 Suffix B: fast opening without pressure regulator
 Suffix C: softlite opening with pressure regulator
 Suffix D: softlite opening without pressure regulator

Main gas connection

See table 1.
 $\frac{3}{8}$ " or $\frac{1}{2}$ " straight or elbow flanges are according to the torsion and bending stress of EN 126 group 2
 Side outlet (optional) can be mounted directly to a burner manifold.

Pilot gas connection (where applicable)

M8 x 1 thread for 4 mm outer diameter tubing.

Pressure feedback connection

Servo pressure regulator has an M5 threaded hole for connection between pressure regulator and combustion chamber of the appliance.

Ambient temperature

5 ... 140° F

Dimensions

See fig. 1.

Pressure regulation function

Class A according to EN 88

Outlet pressure

Outlet pressure is pressure drop across the main burner orifice.

Outlet pressure range

0.022 ... 0.29 psi (0.6 ... 8" w.c.)
 0.029 ... 0.46 psi (0.8 ... 13" w.c.)

Maximum inlet pressure

$\frac{1}{2}$ psi

Minimum regulation capacity

35000 BTU at $\Delta p = 0.0072$ psi (0.2" w.c.) across main burner orifice at 0.5 psi operating pressure maximum.

Minimum operating gas pressure

0.22 psi (15 mbar)

Maximum operating gas pressure

The P_{max} $\frac{1}{2}$ psi (35 mbar) indication on the housing of the gas control is the maximum inlet pressure at which the gas control functions safely.

APPLICATION

The VK41../VK81.. gas controls for Combined Valve and Ignition system (CVI) have specially been developed for application in gas fired appliances with either intermittent pilot (IP) or direct burner ignition (DBI).

For this system, the VK41../VK81.. series gas controls have been designed to have the S4565/S4575/S4585 series ignition control attached directly onto the valve.

The combined system then provides programmed safe light up, flame supervision and regulation of gas flow to the main burner and/or pilot burner of the appliance.

The VK41.5/VK81.5 series gas controls can also be used as stand alone in direct burner applications. A plug with an integrated rectifier circuit then has to be used (order number 45.900.441-).

The VK41../VK81.. gas controls can handle the three gas families, manufactured gas, natural gas and LP gas.

The VK41../VK81.. gas controls are approved in accordance with:

AGA; (ANSI Z21.78-1997)
 CGA; (CAN/CGA-6.20-M97, 1997).

DESCRIPTION

The VK41../VK81.. gas controls hold a first electric on/off direct operator for opening the safety valve of class B according to EN 161 and a second electric on/off servo operator of class C or J according to EN 161.

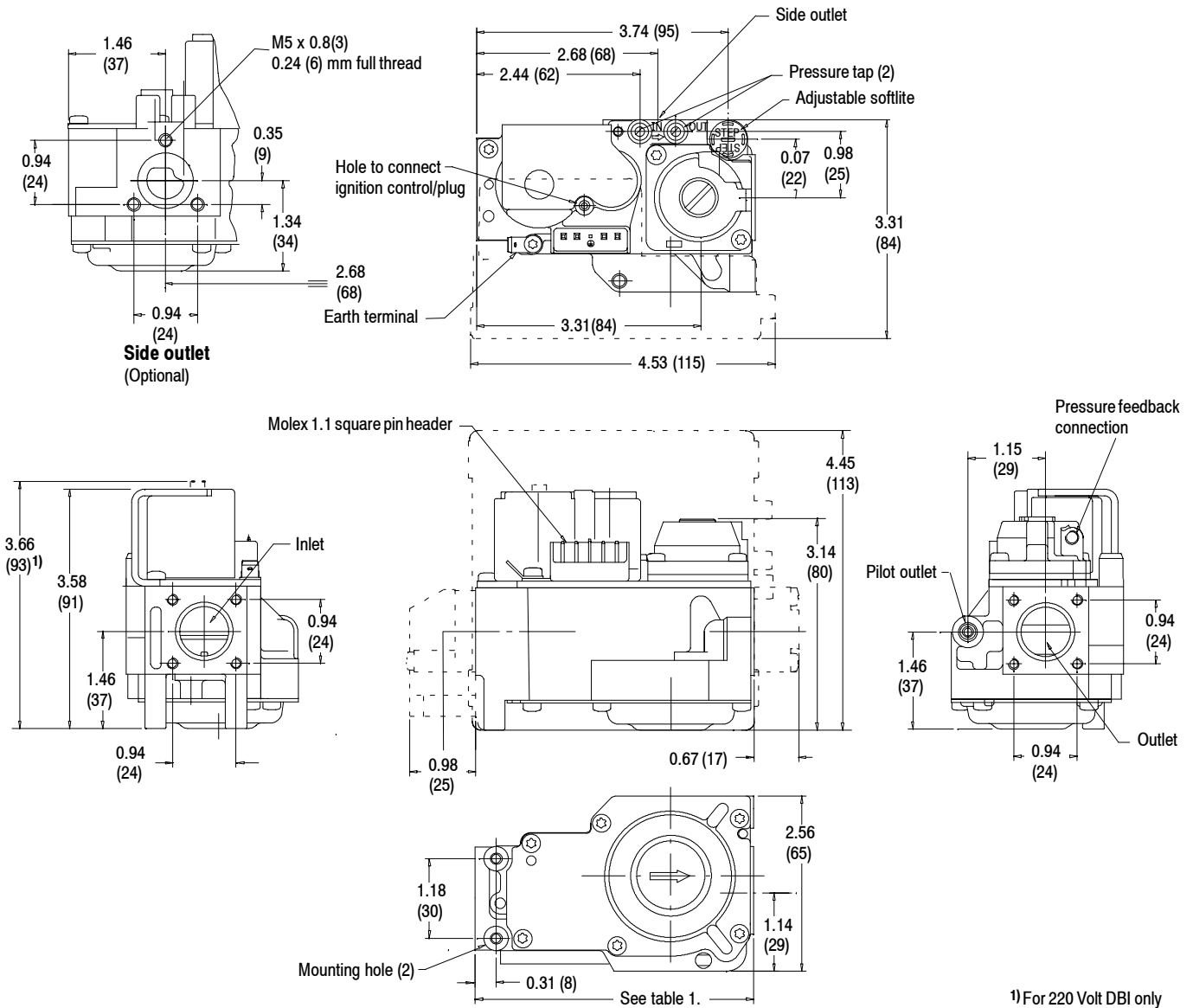

Fig. 1. Dimensions in inches (mm)

Table 1. Standard valve connection

Inlet	End outlet	Side outlet	Body length inch (mm)
Ø 0.73"/18.6 mm, flanged	Ø 0.73"/18.6 mm, flanged	--	4.13 (105)
Ø 0.73"/18.6 mm, flanged	--	Ø 0.55"/14 mm, flanged	4.13 (105)
Internal 3/8" ISO 7-1	--	Ø 0.55"/14 mm, flanged	4.53 (115)
Internal 1/2" ISO 7-1	--	Ø 0.55"/14 mm, flanged	4.53 (115)
Internal 1/2" ISO 7-1	Internal 1/2" ISO 7-1	--	4.53 (115)
Internal 1/2" NPT	Ø 0.73"/18.6 mm, flanged	--	4.53 (115)

Valve classification

VK411./VK811.: Class B + C
 VK410./VK810.: Class B + J

Capacity

99309 BTU at $\Delta p = 1''$ w.c. for class B + D
 145653 BTU at $\Delta p = 2''$ w.c. for class B + C
 Versions with side outlet have 0.2 m³/h air / 9195.4 BTU lower capacity.

* capacity based on 1050 BTU/ft.³, 0.64 specific gravity natural gas.

Timing

Closing time: < 1 s
 Opening time: < 1 s from start of flow till outlet pressure is 0.015 psi (0.4" w.c.)

Mounting holes

Two mounting holes for thread forming screws are located on the bottom of the gas control.

The four holes at inlet and outlet for mounting a flange on the gas control are provided with M4 thread with a minimum of 6 mm full thread.

In case of side outlet three three holes for mounting a flange are provided with M5 thread with a minimum of 6 mm full thread.

Electrical data

Supply voltage

VK41...: 220 ... 240 Vrac

VK41...: 220 ... 240 Vac, 50/60 Hz using rectifier

VK81...: 24 Vrac

VK81...: 24 Vac, 50/60 Hz using rectifier

Current and power consumption

See table 4.

Electrical connection diagram

Both coils have to be connected separately to the 24 Volt rac supply in parallel. See fig. 2.

Enclosure according IEC 259

IP 40

IP 44 with rectifier plug

Electrical connection

Molex 1.1 square pin headers.

For **stand alone AC** applications in **direct burner ignition** applications a plug with rectifier circuit has to be used.

Rectifier plug

The 220/240 V and 24 V versions of the VK41.../VK81.. series gas controls can be connected to any standard **DBI** control with a 220/240 Vac or 24 Vac output by using a rectifier plug 45.900.441-

For rectifier plugs see Product Handbook EN2R-9004

IMPORTANT

Warranty claims are not accepted if not the specified plug/rectifier circuit is used.

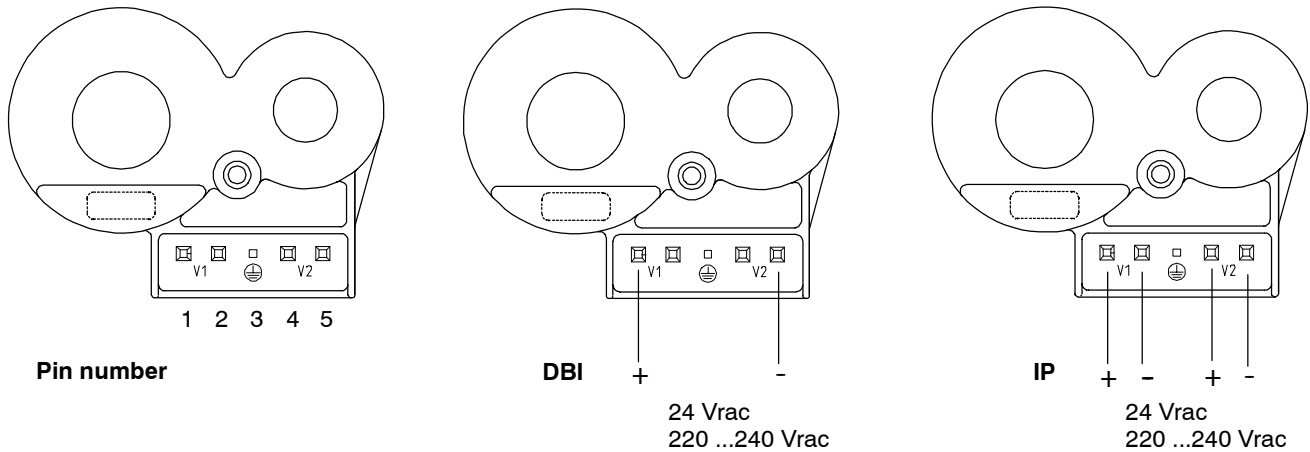

Fig. 2. Coil connection

Table 2. Electrical connection for Direct Burner Ignition systems

Supply voltage	Coil indication	Rectifier circuit position	Coil connection (See fig. 2.)	Valve indication
24 Vac, 50/60 Hz	24 Vrac	External	Series connection pin 1 and pin 5 or plug 45.900.441-	VK 81.5
24 Vac, 50/60 Hz	24 Vrac	In plug	Plug 45.900.441-	VK 81.5
220 ... 240 Vac, 50/60 Hz	220 ... 240 Vrac	In S4565	S4565 type or plug 45.900.441-	VK 41.5
220 ... 240 Vac, 50/60 Hz	220 ... 240 Vrac	In plug	Plug 45.900.441-	VK 41.5
220 ... 240 Vac, 50/60 Hz	220 ... 240 Vrac	External	Series connection pin 1 and pin 5	VK 41.5

Table 3. Electrical connection for Intermittent Pilot ignition systems

Supply voltage	Coil indication	Rectifier circuit position	Coil connection (See fig. 2.)	Valve indication
24 Vac, 50/60 Hz	24 Vrac	External	Parallel connection pin 1/2 and pin 4/5	VK 81.0
220 ... 240 Vac, 50/60 Hz	220 ... 240 Vrac	In S4565 and S4585 types	S4565 and S4585 types	VK 41.0
220 ... 240 Vac, 50/60 Hz	220 ... 240 Vrac	External	Parallel connection pin 1/2 and pin 4/5	VK 41.0

Table 4. Power consumption (W) and current (mA)

Supply voltage	Power consumption				Current			
	Nominal voltage		110% nominal voltage		Nominal voltage		110% nominal voltage	
	1 st operator	1 st + 2 nd operator	1 st operator	1 st + 2 nd operator	1 st operator	1 st + 2 nd operator	1 st operator	1 st + 2 nd operator
DBI system								
24 Vac, 50/60Hz	--	9.2	--	11	--	424	--	466
220 Vac, 50/60Hz	--	9.4	--	11.4	--	48	--	52
240 Vac, 50/60Hz	--	11.2	--	13.6	--	52	--	57
IP system								
24 Vac, 50/60Hz	6.7	6.7 + 3.1	8.0	8.0 + 3.7	309	309 + 143	340	157
220 Vac, 50/60Hz	9.1	4.8	11	5.8	46	24	51	27
240 Vac, 50/60Hz	10.9	5.7	13.1	6.9	50	26	55	29
220 Vac, 50/60Hz	7	7 + 3.5	8.3	8.3 + 4.2	31	31 + 18.0	35	35 + 18.2
240 Vac, 50/60Hz	8.0	8.0 + 4.0	9.6	9.6 + 4.4	35	35 + 18.5	38.4	38.4 + 18.6

Main valve opening characteristics

Softlite versions (See table 5.)

NOTE: For softlite versions the softlite pressure can be adjusted from the rated softlite up to the desired value, but max. up to 8.02" w.c. (20 mbar)

The 2nd valve with class B closing force can also be provided with reduced opening speed, the max. dead time is then 1 s max. and the outlet pressure shall reach 2" w.c (5 mbar) within 3 s from start of flow.

Fast opening versions

For class C or J closing force of the 2nd valve the dead time is 0.5 s max. and the outlet pressure shall reach 80% of the rated flow within 1 s from start of flow.

Table 5. Main valve (class D only) opening characteristics softlite versions

Softlite number	Inlet pressure (inch w.c.)	Kind of gas	Dead time (s) max		Outlet pressure (inch w.c.) 1.5 s after start of flow (in min. position)	Outlet pressure (inch w.c.) 1.5 s after start of flow (in max. position)
			Upright position	Horizontal position		
3	8	G 20/25	1.8	1.5	0.4 ... 1.4	> 4.8
5 7 9 10	8	G 20/25	1.2	1.0	1 ... 2.4 1.8 ... 3 2.4 ... 3.6 3.6 ... 6	> 4.8
7 9 10	14.8	G 30/31	1.5	1.2	1 ... 2.6 1.8 ... 3.2 3 ... 5.8	> 6.4

* The adjusted outlet pressure will be reached between 5 and 15 seconds from start of flow.

INSTALLATION

When installing this product.....

- 1 Read these instructions carefully. Failure to follow them could damage the product or cause a hazardous condition.
- 2 Check the ratings given in the instructions and on the product to ensure the product is suitable for your application.
- 3 Installer must be a trained, experienced service technician.
- 4 After installation is complete, use these instructions to check out product operation.



WARNING

FIRE OR EXPLOSION HAZARD CAN CAUSE PROPERTY DAMAGE, SEVERE INJURY OR DEATH.

Follow these warnings exactly:

- 1 Disconnect power supply before wiring to prevent electrical shock and/or equipment damage.
- 2 To avoid dangerous accumulation, turn off gas supply at the appliance before starting installation and perform Gas Leak Test after completion of installation.

IMPORTANT

These gas controls are shipped with protective seals over inlet and outlet tappings.

Do not remove seals until the ready to connect piping.

If M5 air pressure connection is not to be used, it is recommended to push a dust cap (order nr. 45.900.426-001) into the hole.

Follow the appliance manufacturer's instructions if available; otherwise, use the instructions provided below.

Install flanges to control

- 1 Choose the appropriate flange for your application.
- 2 Remove seal over gas control inlet or outlet.
- 3 Assure that the "O"-ring is fitted in the groove of the flange. If the "O"-ring is not attached or is missing, do not use the flange.
- 4 With "O"-ring facing the valve, align the screw holes on the control with the holes in the flange. Insert and tighten the screws provided with the flange.
- 5 Tighten the screws to 26 inch-pounds (3 Nm) of torque to provide a gas tight seal.

Complete instructions below for installing piping, installing gas control and wiring. Make certain the leak test you perform on the control after completing the installation includes leak testing the adapters and screws. If you use a wrench on the gas control after flanges are installed, use the wrench only on the flange, not on the control.

Choose gas control location

The gas control is mounted in the appliance vestibule on the gas manifold. If this is a replacement application, mount the gas control in the same location as the old gas control.

Do not locate the gas control where it may be affected by steam cleaning, high humidity, dripping water, corrosive chemicals, dust or grease accumulation, or excessive heat. To ensure proper operation, follow these guidelines:

- Locate gas control in a well-ventilated area.
- Mount gas control high enough above cabinet bottom to avoid exposure to flooding or spashing water.
- Ensure the ambient temperature ratings for each component.
- Cover gas control if the appliance is cleaned with water, steam, or chemicals to avoid dust and grease accumulation.
- Avoid locating gas control where exposure to corrosive chemical fumes or dripping water are likely.

Install piping to gas control

All piping must comply with local codes and ordinances or with the National Fuel Gas Code (ANSI Z223.1 NFPA NO. 54), whichever applies.

Tubing installation must comply with approved standards and practices.

- 1 Use a sound taper fitting with thread according to ANSI ASME B1201, 1983 or a piece of new, properly reamed pipe, free from chips. If tubing is used, ensure the ends are square, deburred and clean. All tubing bends must be smooth and without deformation. **Do not use teflon tape.**
- 2 Run pipe or tubing to the flange. If tubing is used, obtain a tube-to-pipe coupling to connect the tubing to the control.
- 3 Install sediment trap in the supply line to the gas control
- 4 Take care that dirt cannot enter the gas control during handling.
- 5 Connect the flange to the gas control afterwards. Max. torque on flange screws: 26 inch-pounds (3 Nm)
- 6 Ensure the "O" ring is properly placed in the groove of the flange.

Install gas control

- Mount the gas control 0 ... 90 degrees in any direction from the upright position. Upright position is position with the coil on top.
- Mount the gas control in such a way that gas flows in the direction of the arrow on the bottom of the gas control.
- Connect the flange to the gas control afterwards. Max. torque on flange screws: 26 inch-pounds (3 Nm) (see fig. 5.)
- Ensure the "O" ring is properly placed in the groove of the flange.
- Connect air pressure signal tube to M5 air pressure connection nipple.



WARNING

To avoid decreasing of performance of pressure regulator by pinching off the pressure feedback tubing, it is recommended to use a metal tubing

Pilot gas connection (if applicable)

- Square off the end of tubing and remove burrs.
- Slip compression fitting over 4 mm tubing.
- Insert tubing into gas control housing until it bottoms, slide fitting into place and turn finger tight.
- Use a wrench to tighten fitting about 1¹/₂ turn beyond finger tight to shear of the olive.

Do not use jointing compound.

Connect other end of tubing to pilot burner according to the manufacturer's instructions.

CAUTION

Do not bend tubing at gas control after compression fitting has been tightened, as this may result in gas leakage at the connection.

Electrical connection

IMPORTANT

Follow the wiring instruction furnished by the appliance manufacturer, if available, or use the general instructions provided below. Where these instructions differ from the appliance manufacturer, follow the appliance manufacturer instructions. Disconnect power supply to prevent electrical shock and/or equipment damage. All wiring must comply with applicable electrical codes and ordinances. Before installing or replacing any control check that type number is correct for the application. Ensure combustion chamber is free of gas before start up. Conduct a thorough check out when installation is completed. Check the power supply rating on the valve and make sure it matches the available supply. Install thermostat and other controls as required. At the first start the ignition control can be in lock out; depress reset button to free control.

Mounting of rectifier plug (See fig 3.)

Do not overtighten the screw.
Tighten to 3.5 inch-pounds (0.4 Nm) maximum

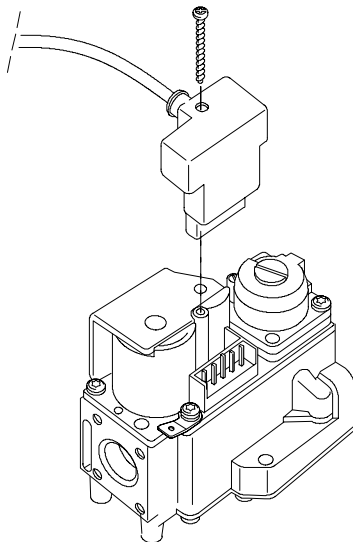

Fig. 3. Connect rectifier plug to gas control

CAUTION

To ensure a safe closing of the valves, it is essential that voltage over the terminals is reduced to 0 Volt.

Perform gas leak test

WARNING

FIRE OR EXPLOSION HAZARD CAN CAUSE PROPERTY DAMAGE, SEVERE INJURY OR DEATH

Check for gas leaks with rich soap and water solution any time work is done on a gas control. Use an approved leak detection fluid.

Gas leak test

- Paint all pipe connections upstream of the gas control with a rich soap and water solution. Bubbles indicate a gas leak. Use an approved leak detection fluid.
- If a gas leak is detected, tighten the pipe connection.
- Stand clear while lighting the main burner to prevent injury caused from hidden gas leaks, which could cause flashback in the appliance vestibule. Light the main burner.
- With the main burner in operation, paint all pipe joints (including adapters) and gas control inlet and outlet with rich soap and water solution.
- If another gas leak is detected, tighten adapter screws, joints and pipe connections.
- Replace the part if gas leak can not be stopped.

CAUTION

Keep soap and water solution away from electrical connections.

Light the pilot burner flame (if applicable)

Follow the appliance manufacturer instructions or set the thermostat setting above room temperature to call for heat.

Light the main burner

Follow the appliance manufacturer instructions or set the thermostat setting above room temperature to call for heat.

ADJUSTMENTS

WARNING

Adjustments must be made by qualified persons only. If the appliance manufacturer supplies checkout and/or service and maintenance instructions carefully follow them. If such instructions are not provided then use the procedure outlined below.

CAUTION

- 1 Do not exceed the input rating stamped on the appliance nameplate or manufacturer recommended burner orifice pressure for the size of orifices used. Assure the main burner primary air supply is properly adjusted for complete combustion (refer to the appliance manufacturer instructions).
- 2 **IF CHECKING GAS INPUT BY CLOCKING THE GAS METER:**
 - Assure that the only gas flow through the meter is that of the appliance being tested.
 - Assure that other appliances are turned off and their pilot burners are extinguished (or deduct their gas consumptions from the meter reading).
 - Convert the flow rate to Btu/h (form 70-2602) and compare to the Btu/h input rating on the appliance name plate.

⑨ IF CHECKING GAS INPUT WITH A MANOMETER (PRESSURE GAUGE):

- Assure the gas control is energized before connection is made between the the outlet pressure tap and the manometer.
- Convert the flow rate to Btu/h (form 70-2602) and compare to the Btu/h input rating on the appliance name plate.
- De-energize the gas control when removing the manometer and
- Shutt off the gas supply at the appliance before disconnecting the manometer and re-tigthen the pressure tap screw.
Max. torque on screw: 9 inch-pound (1 Nm)
- Perform the gas leak test at inlet and outlet pressure tap.

Pressure tap

The gas control is provided with pressure taps of 9 mm outer diameter.

When checking the pressure undo the screw a half turn and slip tube over nipple.

Ensure that screw is retightened after making test.

Max. torque on screw: 9 inch-poundf (1 Nm)

Outlet pressure adjustment on/off versions (see fig. 1.)

- Disconnect pressure feedback connection (if applicable)
- Start-up appliance in order to have gas input to burner.
- Check gas input to the appliance using a clocking gas meter or alternatively a pressure gauge connected to the outlet pressure tap.
- Remove cap screw to expose pressure regulator adjustment screw.
- Slowly turn adjustment screw with a small screw driver until the burner pressure required is recorded on the pressure gauge. Turn adjustment screw clockwise to increase or counter-clockwise to decrease gas pressure to the burner.
- For non-regulating mode (LP gas) turn adjustment screw clockwise until it stops.
- Replace pressure regulator cap screw.
- Connect pressure feedback connection (if applicable).

Check of slow opening (Softlite)

The softlite pressure is factory set.

Check burner performance at this pressure observing burner ignition and flame characteristics.

Burner should ignite promptly and without flash back to orifice and all ports should remain lit.

Cycle burner several times (wait 15 seconds between cycles to allow servo system to resume slow open action).

Repeat check of slow opening after allowing the appliance to cool down.

Adjustable Softlite

For versions with adjustable softlite the pressure can be adapted to optimise the ignition or to change over to another gas type.

- Check the ignition as described under "check of slow opening".
- Turn the appliance off.
- Remove the dust cap.
- Turn the adjustment screw one step in the direction "MAX" to increase or in the direction "MIN" to decrease the softlite pressure.

NOTE: Change over from natural gas to LP gas by turning from minimum. to maximum.

- Start up the appliance and check the ignition, and repeat the adjustment if needed.
- Replace dust cap.

CHECKOUT

Check safety shutdown performance



WARNING

FIRE OR EXPLOSION HAZARD CAN CAUSE PROPERTY DAMAGE, SEVERE INJURY OR DEATH

Perform the safety shutdown test any time work is done on a gas system.

Final checkout

After any adjustment set appliance in operation and observe several complete cycles to ensure that all burner components function correctly.

MAINTENANCE AND SERVICE

Under normal circumstances no maintenance or service is required.



WARNING

FIRE OR EXPLOSION HAZARD CAN CAUSE PROPERTY DAMAGE, SEVERE INJURY OR DEATH

Do not disassemble the gas control; it contains no replaceable components.

Attempted disassembly or repair may damage the gas control.

Screws on the gas control that have been sealed must never be removed.

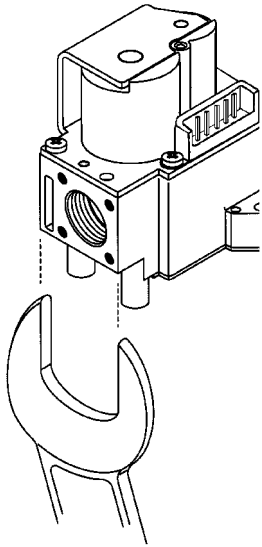

Fig. 4. Proper use of wrench

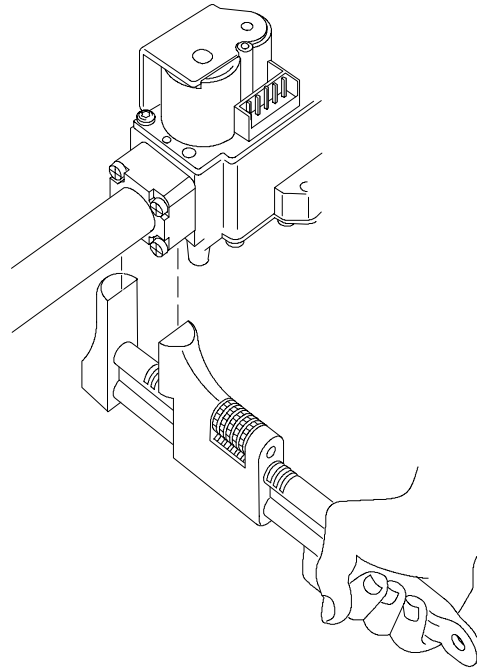

Fig. 5. Proper use of wrench when flange is used