

VK8525M(R)

MODULATING GAS CONTROL "GASTEP"

INSTRUCTION SHEET

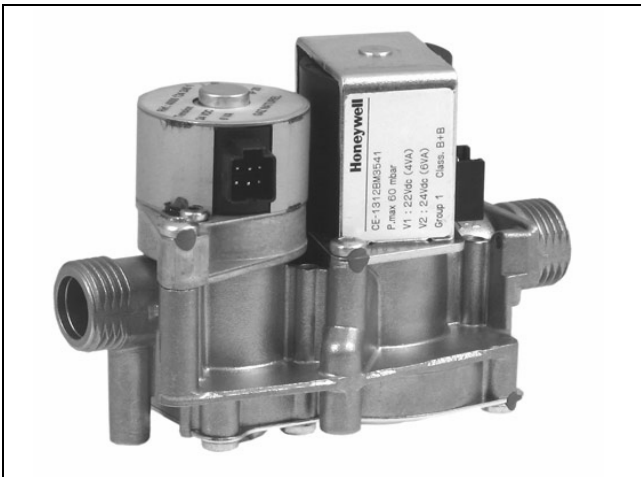

APPLICATION

The Gastep gas control has been developed for modulating gas fired appliances.

The application of the Gastep gas control requires specific control electronics in order to fulfil the safety requirements.

DESCRIPTION

The Gastep gas control comprises:

- an electrically operated on/off safety valve class B
- an electrically operated steppermotor based modulating main valve
- an optional integrated gas pressure regulator in accordance with class C requirement of EN 88.

The Gastep gas control meets the EN 161 and the EN 88 requirements.

SPECIFICATIONS

Model

VK8525M: modulating gas control **without** pressure regulator

VK8525MR: modulating gas control **with** pressure regulator

Dimensions

See fig. 1.

Ambient temperature

-5 ... 70°C

Main gas connection

Connections with G 1/2" external thread fitted with nuts according to ISO 228-1 in combination with applicable sealing(s) withstand the torsion and bending stress of EN 161 group 1

Capacity

Natural gas versions: 3,12 m³/h air minimum at 5 mbar pressure drop

LPG versions without regulator:

1,8 m³/h air minimum at 5 mbar pressure drop

LPG versions with regulator (specials):

1,2 m³/h air at specific conditions:
 - inlet pressure 50 mbar (nominal)
 - outlet pressure 16 mbar

See also capacity curves on page 3.

In the capacity curves, min. and max. are specified.

Operating pressure ranges

Natural gas: 15 ... 30 mbar

LP gas: 25 ... 60 mbar

Maximum inlet pressure

60 mbar

Timing

opening time : < 1 second

closing time : < 1 second

Valve classification

Safety valve: class B

Main valve: class B *

*) The main valve is classified as safety valve class B only, if used in combination with a specific electronic system, performing additional safety checks to the judgement of the notified body and meeting the requirements for safety electronics according EN298 !

Electrical data

Safety valve operator

Opening voltage: 22 Vdc ± 1.5 Vdc

Hold voltage (regulated): 12 Vdc ± 1.5 Vdc

Power consumption: 4 W maximum

Connection: 2.8 x 0.8 mm tabs

Main valve steppermotor

Supply voltage: 24 Vdc -4/+6Vdc

Power consumption: 6 W maximum

Connection: JST XHDP-06V-1

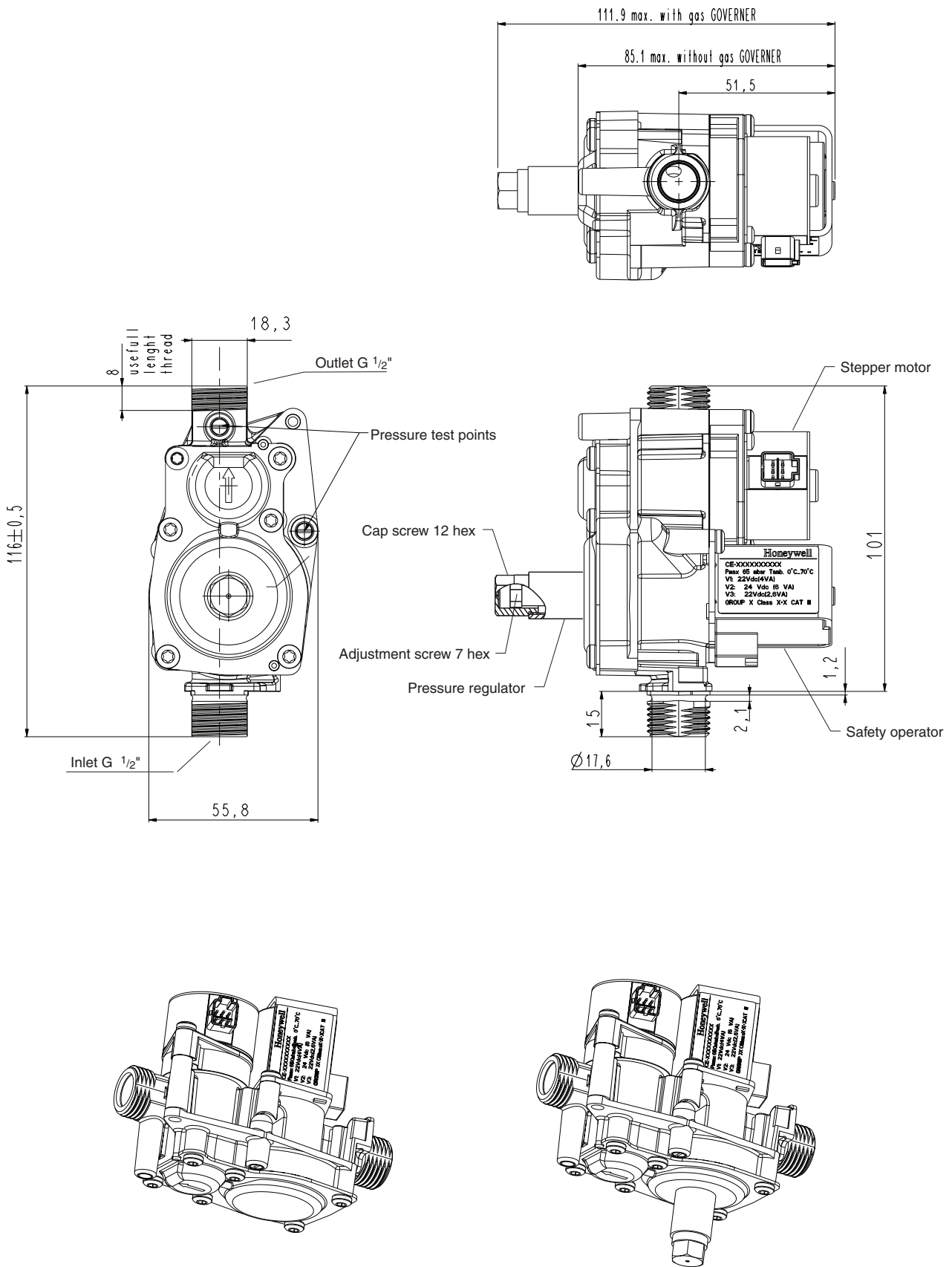

Fig. 1. Dimensional drawing

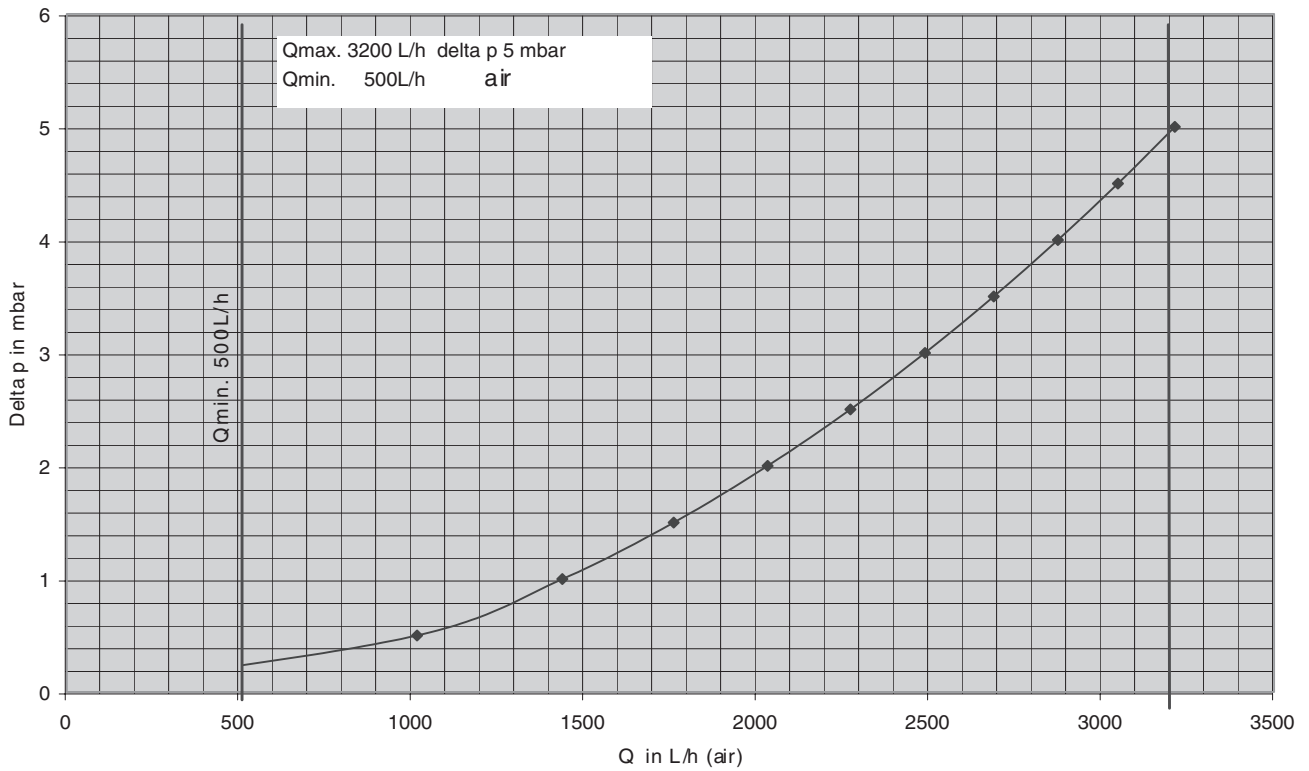

Fig. 2. Nominal capacity curve Natural Gas (regulated versions)

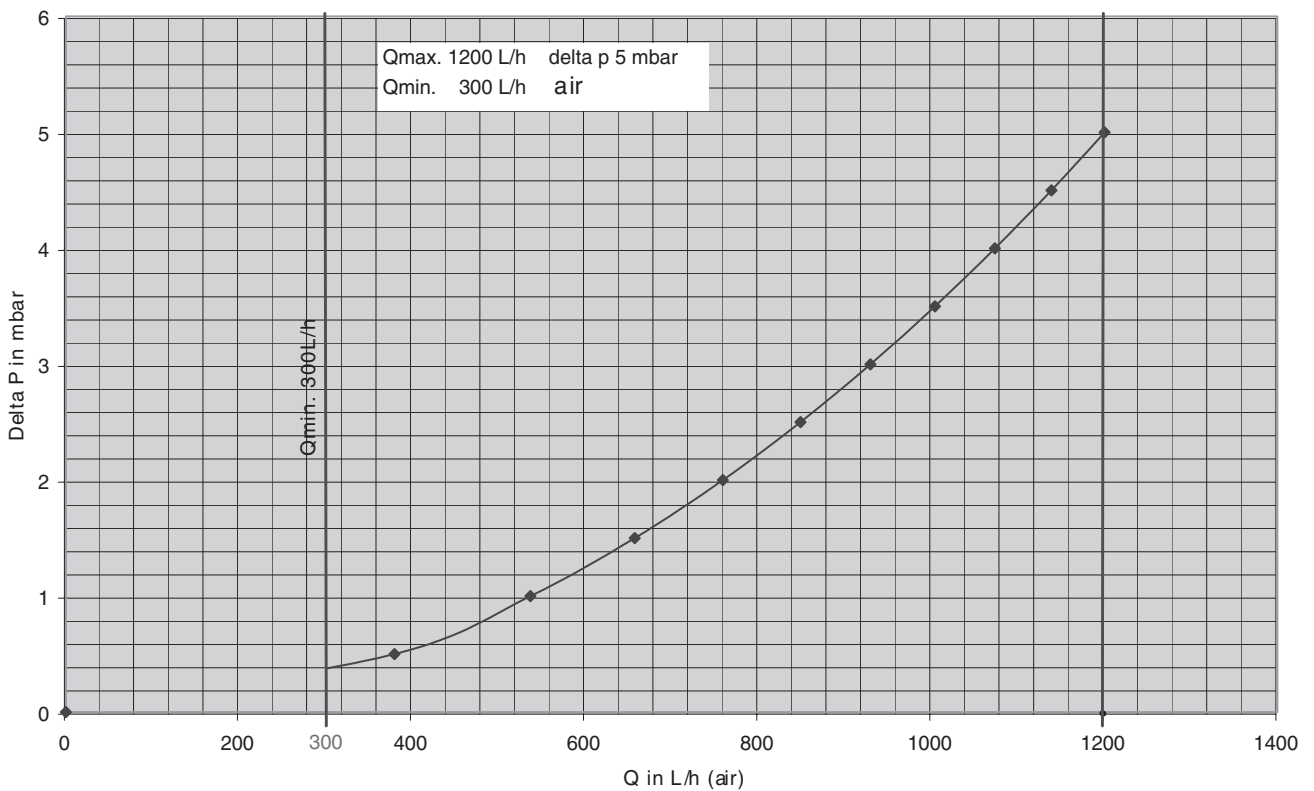

Fig. 3. Nominal capacity curve LP Gas (regulated versions)

INSTALLATION

IMPORTANT

*Take care that installer is a trained experienced service person.
Turn off gas supply before starting installation.
Disconnect power supply to prevent electrical shock and/or equipment damage.
Take care that dirt cannot enter the gas control during handling.
Ensure the gas flows in the same direction as the arrow on the bottom of the gas control.*

Mounting position

The gas control can be mounted 0 to 90 degrees in any direction from the upright position (from the position when the operators are on top).



CAUTION

Do not bend tubing at gas control after compression fitting has been tightened, as this may result in gas leakage at the connection.

Perform gas leak test



WARNING

FIRE OR EXPLOSION HAZARD CAN CAUSE PROPERTY DAMAGE, SEVERE INJURY OR DEATH

Check for gas leaks with a rich soap and water solution any time work is done on a gas control.

Gas leak test

- Paint all pipe connections upstream of the gas control with a rich soap and water solution. Bubbles indicate a gas leak.
- If a gas leak is detected, tighten the pipe connection.
- Stand clear while lighting the main burner to prevent injury caused from hidden gas leaks, which could cause flashback in the appliance vestibule. Light the main burner.

- With the main burner in operation, paint all pipe joints (including adapters) and gas control inlet and outlet with a rich soap and water solution or an approved leak detection fluid.
- If another gas leak is detected, tighten adapter screws, joints and pipe connections.
- Replace the part if gas leak can not be stopped.



CAUTION

Keep soap and water solution away from electrical connections.

Electrical connections

IMPORTANT

*Disconnect power supply to prevent electrical shock and/or equipment damage.
Wiring must be in accordance with local regulations.
The appliance manufacturer's instructions should always be followed.
Before installing or replacing any control check that type number is correct for the application.
Ensure combustion chamber is free of gas before start up.
Conduct a thorough check out when installation is completed.*

ADJUSTMENTS AND FINAL CHECKOUT



WARNING

Follow the instructions as supplied by the appliance manufacturer.

Final checkout of the installation

Set appliance in operation after any adjustment and observe several complete cycles to ensure that all burner components function correctly.

Honeywell

Manufactured for and on behalf of the Environmental and Combustion Controls Division of Honeywell Sàrl, Switzerland by its Authorized Representative:

Automation and Control Solutions

Combustion Controls Europe

Honeywell BV

Phileas Foggstraat 7

7821 AJ Emmen

The Netherlands

Tel.: +31 (-)591 695911

Fax: +31 (-) 591 695200

<http://europe.hbc.honeywell.com>