

## VK41..VK81..M/N

### GAS CONTROLS WITH ELECTRIC MODULATING PRESSURE REGULATOR FOR COMBINED VALVE AND IGNITION SYSTEM

#### INSTRUCTION SHEET



The build on Modureg V7335 is designed to work together with the W9335 modulating control, W4115 driver, a T7335 thermistor temperature sensor and an advanced range of micro computer based modulating controls.

The VK41../VK81..M,N gas controls are approved in accordance with:

AGA; (ANSI Z21.78-1997)

CGA; (CAN/CGA-6.20-M97, 1997)

The VK41../VK81..M/N gas controls can handle the three gas families, manufactured gas, natural gas and LP gas.

### DESCRIPTION

The VK41../VK81..M/N gas control holds a first electric on/off direct operator for opening the safety valve of class B according to EN 161 and a second electric on/off servo operator of class C or J according to EN 161.

### SPECIFICATIONS

#### Model

VK41.0: 220 ... 240 Vrac

VK41.5: 220 ... 240 Vrac without pilot burner connection

VK81.0: 24 Vrac

VK81.5: 24 Vrac without pilot burner connection

Suffix M: fast opening with electric modulating pressure regulator

Suffix N: softlite opening with electric modulating pressure regulator

#### Main gas connection

See table 1.

$\frac{3}{8}$ " or  $\frac{1}{2}$ " straight or elbow flanges are according to the torsion and bending stress of EN 126 group 2

Side outlet (optional) can be mounted directly to a burner manifold.

#### Pilot gas connection (where applicable)

M8 x 1 thread for 4 mm outer diameter tubing.

#### Pressure feedback connection

M5 threaded hole for connection between the Modureg and the combustion chamber of the appliance.

#### Ambient temperature

5 ... 140° F

#### Dimensions

See fig. 1.

#### Pressure regulation function

Class A according to EN 88

#### Outlet pressure

Outlet pressure is pressure drop across the main burner orifice.

### APPLICATION

The VK41../VK81..M/N gas controls for Combined Valve and Ignition system (CVI) have specially been developed for application in gas fired appliances with either intermittent pilot (IP) or direct burner ignition (DBI).

For this system, the VK41../VK81..M/N series gas valves have been designed to have the S4565/S4575/S4585 series ignition control attached directly onto the valve.

The combined system then provides programmed safe light up, flame supervision and regulation of gas flow to the main burner and/or pilot burner of the appliance.

The VK41../VK81..M/N gas control can also be used as stand alone in direct burner applications.

A plug with an integrated rectifier circuit then has to be used (order number 45.900.441-).

The VK41../VK81..M,N gas control with the V7335A electric modulating pressure regulator (Modureg) has the following functions:

- **Servo pressure regulation**  
Outlet pressure is held at a constant value regardless of fluctuations of input pressure.
- **Modulating control**  
Between minimum and maximum outlet pressure gas supply to the appliance is dependent on the electrical signal to the modulating coil.
- **Mechanical limitation of outlet pressure**  
The minimum and maximum burner pressures are mechanically adjusted to guarantee good burner performance in case the modulating control should become out of range.

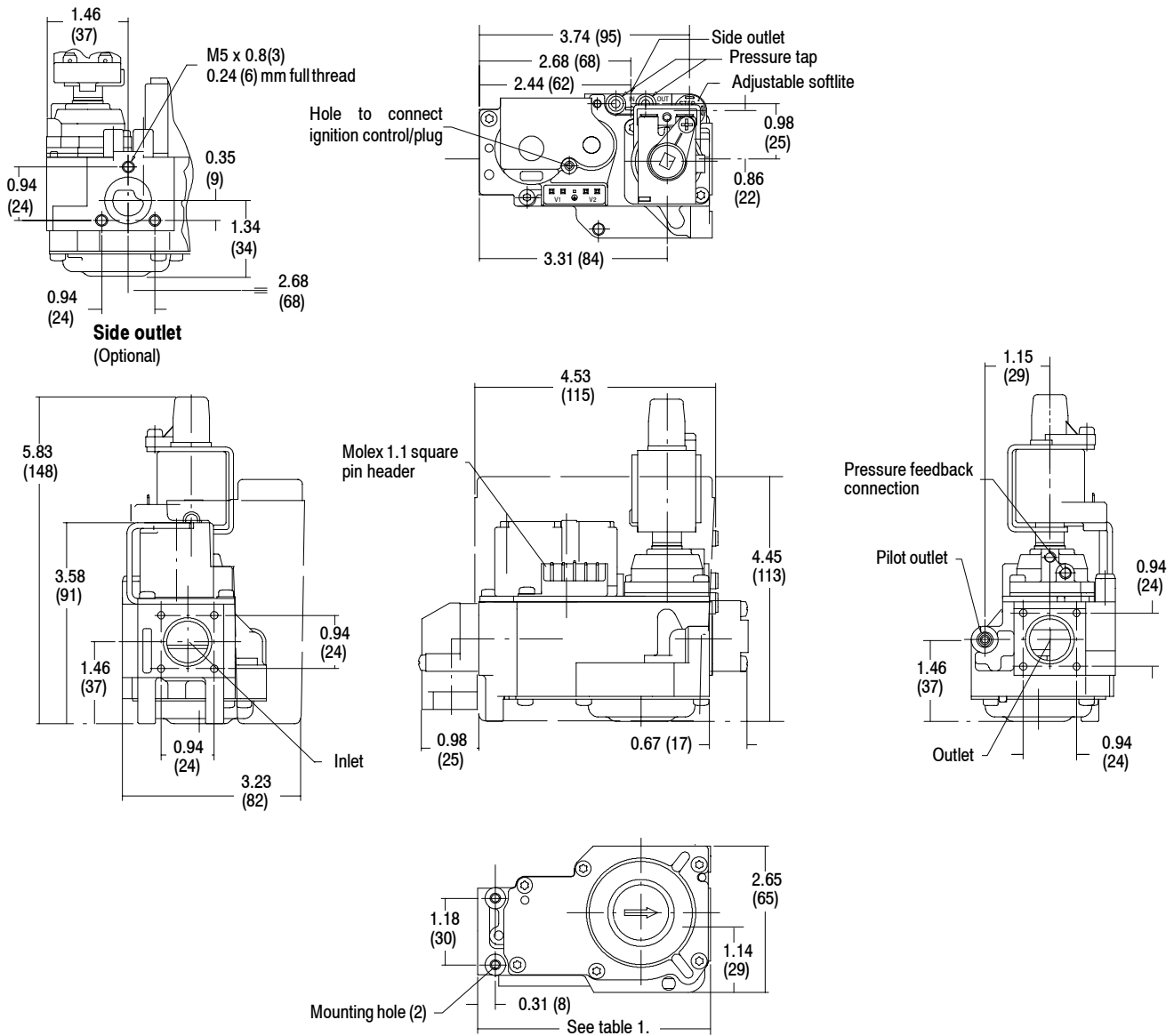

Fig. 1. Dimensional drawing in inch (mm)

Table 1. Standard valve connection

Inlet	End outlet	Side outlet	Body length inch (mm)
Ø 0.73"/18.6 mm, flanged	Ø 0.73"/18.6 mm, flanged	--	4.13 (105)
Ø 0.73"/18.6 mm, flanged	--	Ø 0.55"/14 mm, flanged	4.13 (105)
Internal 3/8" ISO 7-1	--	Ø 0.55"/14 mm, flanged	4.13 (105)
Internal 1/2" ISO 7-1	--	Ø 0.55"/14 mm, flanged	4.13 (105)
Internal 1/2" ISO 7-1	Internal 1/2" ISO 7-1	--	4.13 (105)
Internal 1/2" NPT	Ø 0.73"/18.6 mm, flanged	--	4.13 (105)

**Outlet pressure range**

0.022 ... 0.29 psi (0.6 ... 8" w.c.)  
 0.029 ... 0.46 psi (0.8 ... 13" w.c.)

**Maximum inlet pressure**

1/2 psi

**Minimum regulation capacity**

35000 BTU at Δp= 0.0072 psi (0.2" w.c.) accross main burner orifice at 0.5 psi operating pressure maximum.

**Minimum operating gas pressure**

0.22 psi

**Maximum operating gas pressure**

The P<sub>max</sub> 1/2 psi indication on the housing of the gas control is the maximum inlet pressure at which the gas control functions safely.

**Valve classification**

VK410./VK810.: B + J  
 VL811./VK811.: B + C

**Table 2. Pressure rating Modureg**

Pressure range (inch w.c.)	Identification	Min. outlet pressure range		Max. outlet pressure range (inch w.c.)
		Coil sideways	Coil upwards	
0.6 ... 8	grey cover	0.6 ... 6	0.8 ... 6	(min setting + 1.2) ... 8
1.2 ... 13	yellow cover	1.2 ... 10	1.6 ... 10	(min setting + 2) ... 13

**Capacity**

99309 BTU at  $\Delta p = 1''$  w.c. for class B + J  
 145653 BTU at  $\Delta p = 2''$  w.c. for class B + C  
 Versions with side outlet have 9195.4 BTU lower capacity.  
 NOTE: Capacity based on 1050 BTU/ft.<sup>3</sup>, 0.64 specific gravity natural gas.

**Timing**

Closing time: < 1 s  
 Opening time: < 1 s from start of flow till outlet pressure is 0.015 psi (0.4'' w.c.)

**Mounting holes**

Two mounting holes for thread forming screws are located on the bottom of the gas control.

The four holes at inlet and outlet for mounting a flange on the gas control are provided with M4 thread with a minimum of 6 mm full thread.

In case of side outlet three three holes for mounting a flange are provided with M5 thread with a minimum of 6 mm full thread.

**Electrical data**

**Supply voltage**

VK41...: 220 ... 240 Vrac  
 VK41...: 220 ... 240 Vac, 50/60 Hz using rectifier  
 VK81...: 24 Vrac  
 VK81...: 24 Vac, 50/60 Hz using rectifier

**Current and power consumption**

See table 5.

**Electrical rating Modureg**

Coil		Direct current (mA)	Resistance at 20 °C (Ω)
Voltage (Vdc)	Color		
15	white	50 ... 250	47.7 ... 52.3
28	green	30 ... 165	120 ... 130

**Enclosure according IEC 259**

IP 40

**Electrical connection**

Gas control: Molex 1.1 square pin headers.

Moureg: quick connect terminals which are suitable for 1/4'' (6.3 mm) receptacles e.g. series "250" fasteners.

**Rectifier plug**

The 220/240 V and 24 V versions of the VK41.../VK81... series gas controls can be connected to any standard DBI control with a 220/240 Vac or 24 Vac output by using a rectifier plug 45.900.441-  
 For rectifier plugs see Product Handbook EN2R-9004

**IMPORTANT**

*Warranty claims are not accepted if not the specified plug/rectifier circuit is used.*

**Table 3. Electrical connection for Direct Burner Ignition systems**

Supply voltage	Coil indication	Rectifier circuit position	Coil connection (See fig. 2.)	Valve indication
24 Vac, 50/60 Hz	24 Vrac	External	Series connection pin 1 and pin 5 or plug 45.900.441-029	VK 81.5
24 Vac, 50/60 Hz	24 Vrac	In plug	Plug 45.900.441-	VK 81.5
220 ... 240 Vac, 50/60 Hz	220 ... 240 Vrac	In S4565	S4565 type or plug 45.900.441-	VK 41.5
220 ... 240 Vac, 50/60 Hz	220 ... 240 Vrac	In plug	Plug 45.900.441-	VK 41.5
220 ... 240 Vac, 50/60 Hz	220 ... 240 Vrac	External	Series connection pin 1 and pin 5	VK 41.5

**Table 4. Electrical connection for Intermittent Pilot ignition systems**

Supply voltage	Coil indication	Rectifier circuit position	Coil connection (See fig. 2.)	Valve indication
24 Vac, 50/60 Hz	24 Vrac	External	Parallel connection pin 1/2 and pin 4/5	VK 81.0
220 ... 240 Vac, 50/60 Hz	220 ... 240 Vrac	In S4565 and S4585 types	S4565 and S4585 types	VK 41.0
220 ... 240 Vac, 50/60 Hz	220 ... 240 Vrac	External	Parallel connection pin 1/2 and pin 4/5	VK 41.0

**Table 5. Power consumption (W) and current (mA)**

Supply voltage	Power consumption				Current			
	Nominal voltage		110% nominal voltage		Nominal voltage		110% nominal voltage	
	1 <sup>st</sup> operator	1 <sup>st</sup> + 2 <sup>nd</sup> operator	1 <sup>st</sup> operator	1 <sup>st</sup> + 2 <sup>nd</sup> operator	1 <sup>st</sup> operator	1 <sup>st</sup> + 2 <sup>nd</sup> operator	1 <sup>st</sup> operator	1 <sup>st</sup> + 2 <sup>nd</sup> operator
<b>DBI system</b>								
24 Vac, 50/60Hz	--	9.2	--	11	--	424	--	466
220 Vac, 50/60Hz	--	9.4	--	11.4	--	48	--	52
240 Vac, 50/60Hz	--	11.2	--	13.6	--	52	--	57
<b>IP system</b>								
24 Vac, 50/60Hz	6.7	6.7 + 3.1	8.0	8.0 + 3.7	309	309 + 143	340	157
220 Vac, 50/60Hz	9.1	4.8	11	5.8	46	24	51	27
240 Vac, 50/60Hz	10.9	5.7	13.1	6.9	50	26	55	29
220 Vac, 50/60Hz	7	7 + 3.5	8.3	8.3 + 4.2	31	31 + 18.0	35	35 + 18.2
240 Vac, 50/60Hz	8.0	8.0 + 4.0	9.6	9.6 + 4.4	35	35 + 18.5	38.4	38.4 + 18.6

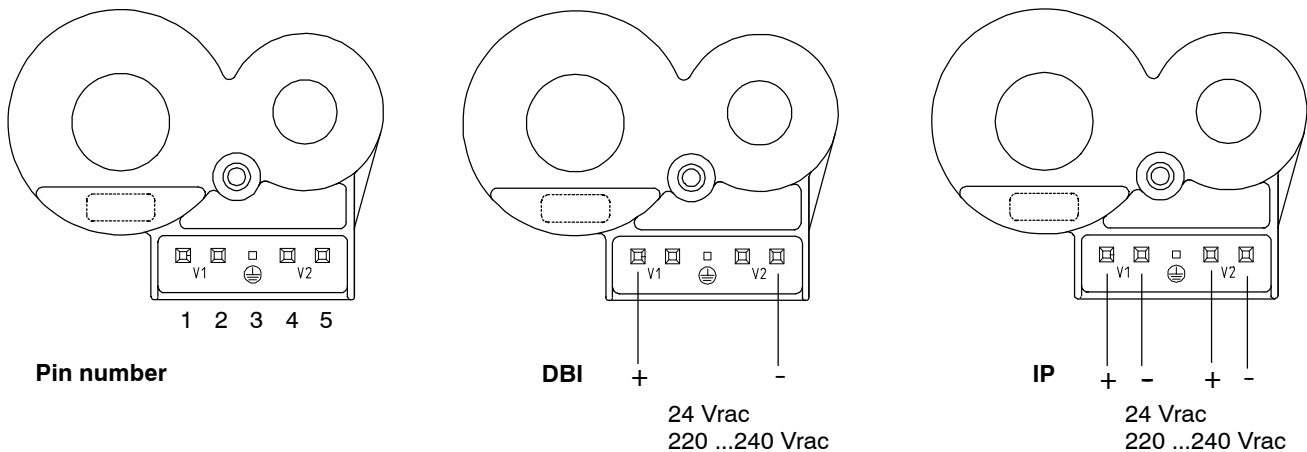

**Fig. 2. Coil connection**

### Main valve opening characteristics

#### Fast opening versions

For class C or J closing force 2<sup>nd</sup> valve the dead time is 0.5 s max. and the outlet pressure shall reach 80 % of the rated flow within 1 s from start of flow.

The class B closing force 2<sup>nd</sup> valve can also be provided with reduced opening speed, the max. dead time is then 1 s max. and the outlet pressure shall reach 2" w.c. within 3 s from start of flow.

#### Softlite versions (See table 6.)

NOTE: For Softlite versions the Softlite pressure can be adjusted from the rated Softlite up to the desired value, but max. up to 8" w.c.

### Modureg modulation characteristics

See fig. 7., 8., 9., 10.

Values are based on increasing current with start at zero.

When current is decreasing from its maximum value the outlet pressure will be higher.

NOTE: Good and reliable performance of the Modureg is not only dependent on the Modureg itself, but also upon the reliability of the modulating control and sensor used.

**Table 6. Main valve (class D only) opening characteristics softlite versions**

Softlit number	Inlet pressure (inch w.c.)	Kind of gas	Dead time (s) max		Outlet pressure (inch w.c.) 1.5 s after start of flow (in min. position)	Outlet pressure (inch w.c.) 1.5 s after start of flow (in max. position)
			Upright position	Horizontal position		
3	8	G 20/25	1.8	1.5	0.4 ... 1.4	> 4.8
5 7 9 10	8	G 20/25	1.2	1.0	1 ... 2.4 1.8 ... 3 2.4 ... 3.6 3.6 ... 6	> 4.8
7 9 10	14.8	G 30/31	1.5	1.2	1 ... 2.6 1.8 ... 3.2 3 ... 5.8	> 6.4

\* The adjusted outlet pressure will be reached between 5 and 15 seconds from start of flow.

## INSTALLATION

### When installing this product.....

- ❶ Read these instructions carefully. Failure to follow them could damage the product or cause a hazardous condition.
- ❷ Check the ratings given in the instructions and on the product to ensure the product is suitable for your application.
- ❸ Installer must be a trained, experienced service technician.
- ❹ After installation is complete, use these instructions to check out product operation.



## WARNING

**FIRE OR EXPLOSION HAZARD CAN CAUSE PROPERTY DAMAGE, SEVERE INJURY OR DEATH.**

Follow these warnings exactly:

- ❶ Disconnect power supply before wiring to prevent electrical shock and/or equipment damage.
- ❷ To avoid dangerous accumulation, turn off gas supply at the appliance before starting installation and perform Gas Leak Test after completion of installation.

### IMPORTANT

*These gas controls are shipped with protective seals over inlet and outlet tapings.*

*Do not remove seals until the ready to connect piping.*

*If M5 air pressure connection is not to be used, it is recommended to push a dust cap (order nr. 45.900.426-001) into the hole.*

*Follow the appliance manufacturer's instructions if available; otherwise, use the instructions provided below.*

### Install flanges to control

- ❶ Choose the appropriate flange for your application.
- ❷ Remove seal over gas control inlet or outlet.
- ❸ Assure that the "O"-ring is fitted in the groove of the flange. If the "O"-ring is not attached or is missing, do not use the flange.

- ❹ With "O"-ring facing the valve, align the screw holes on the control with the holes in the flange. Insert and tighten the screws provided with the flange.
- ❺ Tighten the screws to 26 inch-pounds (3 Nm) of torque to provide a gas tight seal.

Complete instructions below for installing piping, installing gas control and wiring. Make certain the leak test you perform on the control after completing the installation includes leak testing the adapters and screws. If you use a wrench on the gas control after flanges are installed, use the wrench only on the flange, not on the control.

### Choose gas control location

The gas control is mounted in the appliance vestibule on the gas manifold. If this is a replacement application, mount the gas control in the same location as the old gas control.

Do not locate the gas control where it may be affected by steam cleaning, high humidity, dripping water, corrosive chemicals, dust or grease accumulation, or excessive heat. To ensure proper operation, follow these guidelines:

- Locate gas control in a well-ventilated area.
- Mount gas control high enough above cabinet bottom to avoid exposure to flooding or spashing water.
- Ensure the ambient temperature ratings for each component.
- Cover gas control if the appliance is cleaned with water, steam, or chemicals to avoid dust and grease accumulation.
- Avoid locating gas control where exposure to corrosive chemical fumes or dripping water are likely.

### Install piping to gas control

All piping must comply with local codes and ordinances or with the National Fuel Gas Code (ANSI Z223.1 NFPA N0. 54), whichever applies.

Tubing installation must comply with approved standards and practices.

- ❶ Use a sound taper fitting with thread according to ANSI ASME B1201, 1983 or a piece of new, properly reamed pipe, free from chips. If tubing is used, ensure the ends are square, deburred and clean. All tubing bends must be smooth and without deformation. **Do not use teflon tape.**
- ❷ Run pipe or tubing to the flange. If tubing is used, obtain a tube-to-pipe coupling to connect the tubing to the control.

- ③ Take care that dirt cannot enter the gas control during handling.
- ④ Connect the flange to the gas control afterwards.  
Max. torque on flange screws: 26 inch-pounds (3 Nm)
- ⑤ Ensure the "O" ring is properly placed in the groove of the flange.

### Install gas control

- Mount the gas control 0 ... 90 degrees in any direction from the upright position.  
Upright position is position with the coil on top.
- Mount the gas control in such a way that gas flows in the direction of the arrow on the bottom of the gas control.
- Connect the flange to the gas control afterwards.  
Max. torque on flange screws: 26 inch-pounds (3 Nm) (see fig. 5.)
- Ensure the "O" ring is properly placed in the groove of the flange.
- Connect air pressure signal tube to M5 air pressure connection nipple.

### WARNING

To avoid decreasing of performance of pressure regulator by pinching off the pressure feedback tubing, it is recommended to use a metal tubing

#### Pilot gas connection (if applicable)

- Square off the end of tubing and remove burrs.
- Slip compression fitting over 4 mm tubing.
- Insert tubing into gas control housing until it bottoms, slide fitting into place and turn finger tight.
- Use a wrench to tighten fitting about 1 1/2 turn beyond finger tight to shear of the olive.

**Do not use jointing compound.**

Connect other end of tubing to pilot burner according to the manufacturer's instructions.

### CAUTION

Do not bend tubing at gas control after compression fitting has been tightened, as this may result in gas leakage at the connection.

#### Electrical connection

#### IMPORTANT

*Follow the wiring instruction furnished by the appliance manufacturer, if available, or use the general instructions provided below. Where these instructions differ from the appliance manufacturer, follow the appliance manufacturer instructions. Disconnect power supply to prevent electrical shock and/or equipment damage. All wiring must comply with applicable electrical codes and ordinances. Before installing or replacing any control check that type number is correct for the application. Ensure combustion chamber is free of gas before start up. Conduct a thorough check out when installation is completed. Check the power supply rating on the valve and make sure it matches the available supply. Install thermostat and other controls as required.*

*At the first start the ignition control can be in lock out; depress reset button to free control.*

#### Mounting of rectifier plug (See fig 3.)

Do not overtighten the screw.  
Tighten to 3.5 inch-pounds (0.4 Nm) maximum

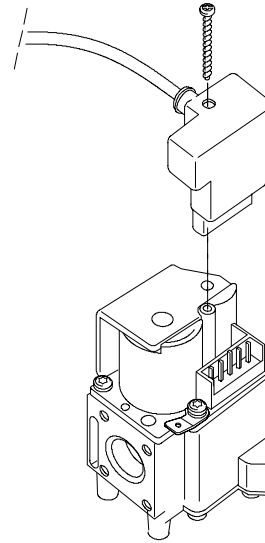

**Fig. 3. Connect rectifier plug to gas control**

### CAUTION

To ensure a safe closing of the valves, it is essential that voltage over the terminals is reduced to 0 Volt.

#### Perform gas leak test

### WARNING

**FIRE OR EXPLOSION HAZARD CAN CAUSE PROPERTY DAMAGE, SEVERE INJURY OR DEATH**

Check for gas leaks with rich soap and water solution any time work is done on a gas control.  
Use an approved leak detection fluid.

#### Gas leak test

- Paint all pipe connections upstream of the gas control with a rich soap and water solution. Bubbles indicate a gas leak. Use an approved leak detection fluid.
- If a gas leak is detected, tighten the pipe connection.
- Stand clear while lighting the main burner to prevent injury caused from hidden gas leaks, which could cause flashback in the appliance vestibule. Light the main burner.
- With the main burner in operation, paint all pipe joints (including adapters) and gas control inlet and outlet with rich soap and water solution.
- If another gas leak is detected, tighten adapter screws, joints and pipe connections.
- Replace the part if gas leak can not be stopped.

### CAUTION

Keep soap and water solution away from electrical connections.

#### Lighth the pilot burner flame (if applicable)

Follow the appliance manufacturer instructions or set the thermostat setting above room temperature to call for heat.

### Ligh the main burner

Follow the appliance manufacturer instructions or set the thermostat setting above room temperature to call for heat.

## ADJUSTMENT



### WARNING

Adjustments must be made by qualified persons only. If the appliance manufacturer supplies checkout and/or service and maintenance instructions carefully follow them. If such instructions are not provided then use the procedure outlined below.

It is recommended that the Modureg is operated a few times to ensure correct setting.

Cap must be removed before any adjustment can be made.

Take care that after any adjustment **cap and "O" ring** are mounted (if applicable)



### CAUTION

- 1 Do not exceed the input rating stamped on the appliance nameplate or manufacturer recommended burner orifice pressure for the size of orifices used. Assure the main burner primary air supply is properly adjusted for complete combustion (refer to the appliance manufacturer instructions).
- 2 **IF CHECKING GAS INPUT BY CLOCKING THE GAS METER:**
  - Assure that the only gas flow through the meter is that of the appliance being tested.
  - Assure that other appliances are turned off and their pilot burners are extinguished (or deduct their gas consumptions from the meter reading).
  - Convert the flow rate to Btu/h (form 70-2602) and compare to the Btu/h input rating on the appliance name plate.
- 3 **IF CHECKING GAS INPUT WITH A MANOMETER (PRESSURE GAUGE):**
  - Assure the gas control is energized before connection is made between the the outlet pressure tap and the manometer.
  - Convert the flow rate to Btu/h (form 70-2602) and compare to the Btu/h input rating on the appliance name plate.
  - De-energize the gas control when removing the manometer and
  - Shutt off the gas supply at the appliance before disconnecting the manometer and re-tigthen the pressure tap screw.  
Max. torque on screw: 9 inch-pound (1 Nm)
  - Perform the gas leak test at inlet and outlet pressure tap.

#### Pressure tap

The gas control is provided with pressure taps of 9 mm outer diameter.

When checking the pressure undo the screw a half turn and slip tube over nipple.

Ensure that screw is retightened after making test.

Max. torque on screw: 9 inch-pound (1 Nm)

### Outlet pressure adjustment

**The minimum pressure setting must first be adjusted to ensure that burner will safely ligh up, then maximum pressure setting can be adjusted.**

**Any adjustmen of minimum pressure setting influences maximum pressure setting.**

#### Adjusting minimum pressure setting (see fig. 6.)

- Disconnect pressure feedback connection (if applicable).
- Connect a suitable pressure gauge to pipe line or to outlet pressure tap of gas control concerned, to measure burner pressure (measuring point must be as near to burner as possible).
- Disconnect electrical connection of Modureg.
- Energize operator, set control in operation and wait until an outlet pressure is recorded on pressure gauge.
- If minimum rate pressure needs adjustment then use a 9 mm wrench to turn adjustment screw for minimum pressure setting clockwise to increase or couter-clockwise to decrease pressure, until the desired minimum outlet pressure is obtained.
- Check if main burner lights easily and reliable at minimum pressure.
- Check maximum pressure setting and readjust if necessary.
- Mount cap and "O"-ring and reconnect pressure feedback connection (if applicable).

#### Adjusting maximum pressure setting (see fig. 6.)

- Disconnect pressure feedback connection (if applicable).
- Connect a suitable pressure gauge to pipe line or to outlet pressure tap of gas control concerned, to measure burner pressure (measuring point must be as near to burner as possible).
- Disconnect electrical connection of Modureg.
- Energize operator, set control in operation and wait until an outlet pressure is recorded on pressure gauge.
- Push shaft gently downwards to the maximum adjustment screw and hold it on.
- If maximum rate pressure needs adjustment then use a 7 mm wrench to turn adjustment screw for maximum pressure setting clockwise to increase or couter-clockwise to decrease pressure, until the desired maximum outlet pressure is obtained. Release shaft.
- Mount cap and "O"-ring and reconnect pressure feedback connection (if applicable).

If minimum and maximum pressures are set, wire Modureg in circuit.

#### Adjusting intermediate pressure setting

Some controls, such as W9335, are able to provide modulating control as well as a fixed setting.

In case this intermediate pressure setting should be set, it is necessary to follow the suppliers instructions regarding the adjustment of the concerned control. It deals with the switching from modulating mode to fixed setting mode which is in most cases is a potentiometer.

The fixed setting mode is very often used for central heating, where on/off adjustable pressure to burner is required.

This intermediate outlet pressure can in general be electrically set as follows:

- Disconnect pressure feedback connection (if applicable).
- Connect a suitable pressure gauge to pipe line or to outlet pressure tap of gas control concerned, to measure burner pressure (measuring point must be as near to burner as possible).
- Energize operator, set control in operation and wait until an outlet pressure is recorded on pressure gauge.

- Make sure Modureg is wired in the circuit.
- Bring system in fixed setting mode.
- Adjust current as low as needed to obtain the lowest pressure by using pressure setting means of control. Mechanical setting of Modureg will prevent too low setting.
- Increase the current until desired pressure is obtained by using pressure setting means of modulating control.
- Mount cap and "O"-ring and reconnect pressure feedback connection (if applicable).

#### Adjustable Softlite

For versions with adjustable softlite the pressure can be adapted to optimise the ignition or to change over to another gas type.

- Check the ignition as described under "check of slow opening".
- Turn the appliance off.
- Remove the dust cap.
- Turn the adjustment screw one step in the direction "MAX" to increase or in the direction "MIN" to decrease the softlite pressure.

NOTE: Change over from natural gas to LP gas by turning from minimum to maximum.

- Start up the appliance and check the ignition, and repeat the adjustment if needed.
- Replace dust cap.

## CHECKOUT

Check safety shutdown performance



## WARNING

**FIRE OR EXPLOSION HAZARD CAN CAUSE PROPERTY DAMAGE, SEVERE INJURY OR DEATH**

Perform the safety shutdown test any time work is done on a gas system.

#### Checkout performance

After any adjustment, set appliance in operation and observe through a complete cycle to ensure that burner system components function correctly.

## MAINTENANCE AND SERVICE

It is recommendable to check yearly the minimum and the maximum setting and readjust them if necessary.



## WARNING

**FIRE OR EXPLOSION HAZARD CAN CAUSE PROPERTY DAMAGE, SEVERE INJURY OR DEATH**

Do not disassemble the gas control; it contains no replaceable components.

Attempted disassembly or repair may damage the gas control.

Screws on the gas control that have been sealed must never be removed.

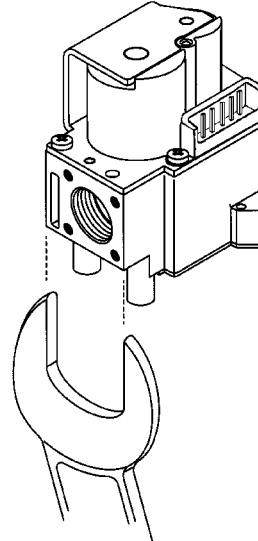

Fig. 4. Proper use of wrench

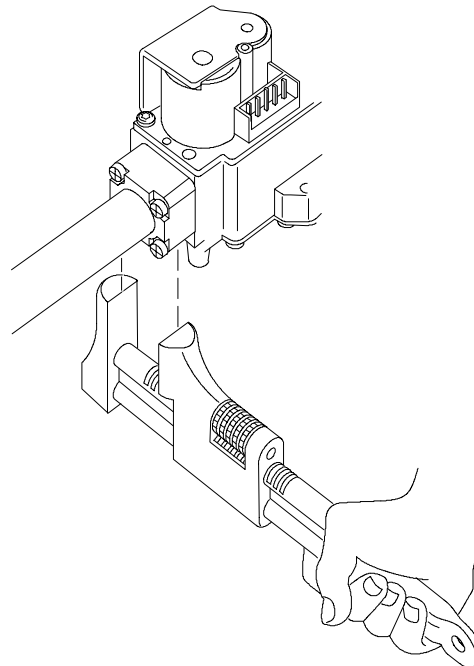
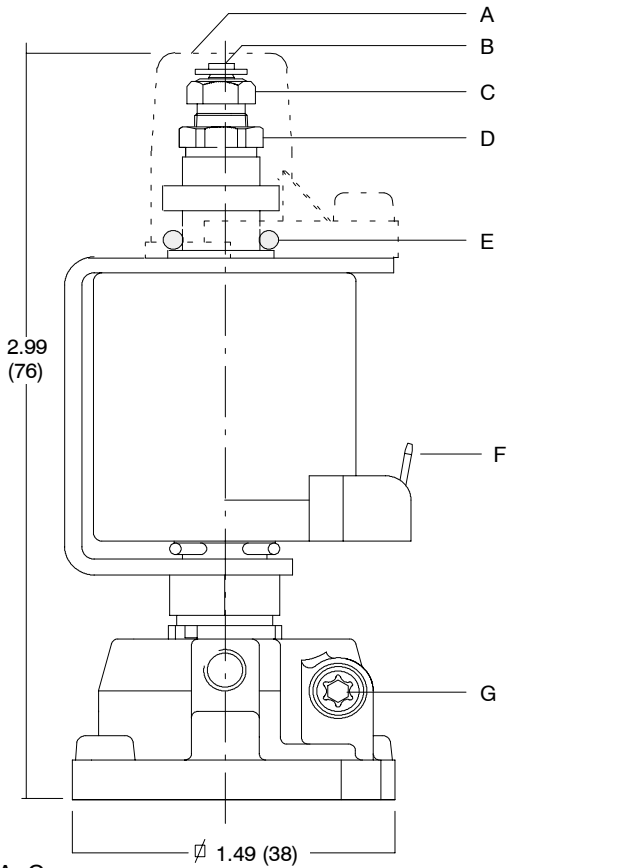

Fig. 5. Proper use of wrench when flange is used





- A Cap
- B Shaft
- C Adjustment screw (9 mm) for maximum pressure setting
- D Adjustment screw (7 mm) for minimum pressure setting
- E "O"-ring
- F 6.3 mm AMP terminals
- G M5 air pressure connection

**Fig. 6. Adjustment points**

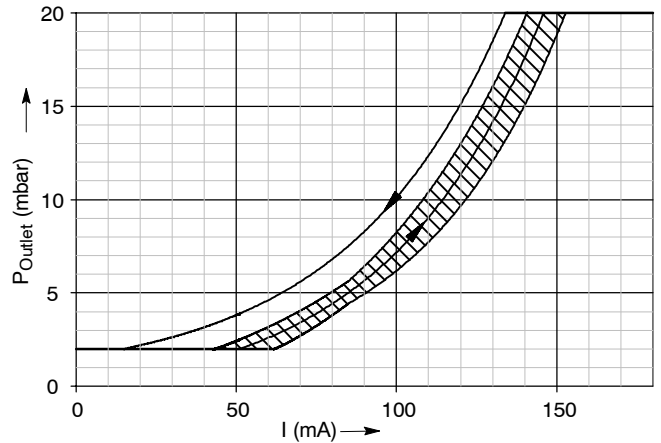

$P_{inlet}$ : 30 mbar; Green coil;  
 $I_{white\ coil} = I_{green\ coil} \cdot 1.52$

**Fig. 7. Pressure range 0.6" ... 8" w.c. Modureg upwards**

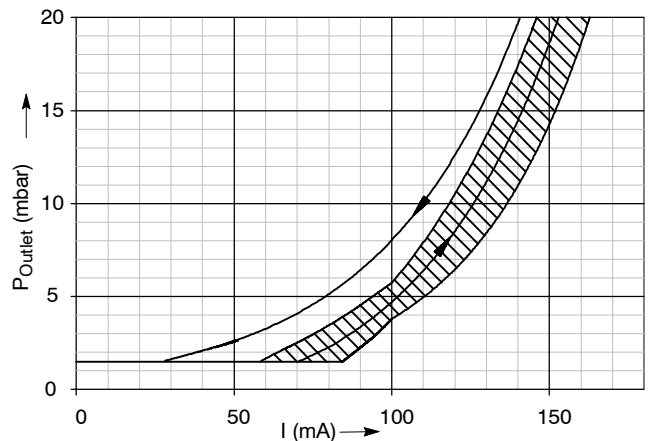

$P_{inlet}$ : 30 mbar; Green coil;  
 $I_{white\ coil} = I_{green\ coil} \cdot 1.52$

**Fig. 8. Pressure range 0.6" ... 8" w.c. Modureg sideways**

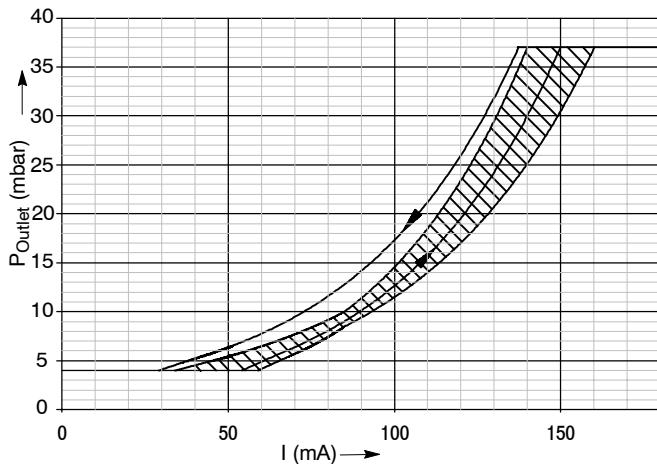

$P_{inlet}$ : 45 mbar; Green coil;  
 $I_{white\ coil} = I_{green\ coil} \cdot 1.52$

**Fig. 9. Pressure range 1.2" ... 13" w.c. Modureg upwards**

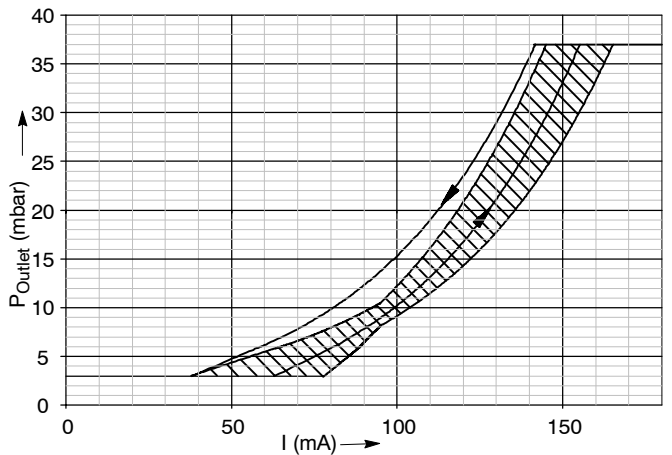

$P_{inlet}$ : 45 mbar; Green coil;  
 $I_{white\ coil} = I_{green\ coil} \cdot 1.52$

**Fig. 10. Pressure range 1.2" ... 13" w.c. Modureg sideways**