



VMRNA

**Automatic vent valve
for gas appliances**

3/4" - 1"½

VMRNA

Contents

Description	2
Features	2
Functioning and application	3
Technical specifications	4
Gas flow chart	5
Ordering information	6
Special versions	7
Options	7
Standards and approvals	7

Description

The VMRNA type is an automatic vent valve for gas appliances. It is suitable for discharging excess or leakage gas into relief lines.

Features

VMRNA valve is a reverse acting solenoid valve: when de-energized, the valve is open (N.O. normally open).

The valves are made of aluminum alloy with connections from 3/4" or 1"½. Pipe connections meet group 2.

Sealings are made of NBR-based rubber certified for use with air gas (EN 549). Suitable for use with air and non-aggressive gases included in the 1st, 2nd and 3rd families (EN 437). Special versions for aggressive gases (e.g. biogas).

Qualified for continuous service (100% ED).

Provided with G1/4 pressure gauge on two sides in inlet chamber to connect manometers, pressure switches, or other gas equipment.

Provided with G1/8 connection to fit an open position indicator switch (see PCS datasheet - This device shall be ordered separately).

VMRNA valve can be integrated in Elektrogas VMM valve, resulting in a very compact system (see VMM datasheet for details).

All components are designed to withstand any mechanical, chemical and thermal condition occurring during typical service. Effective impregnation and surface treatments have been used to improve mechanical sturdiness, sealing and resistance to corrosion of the components.

Valves are 100% tested and fully warranted.



WARNING

This control must be installed in compliance with the rules in force.

Functioning and application

The VMRNA type valve is a vent valve for relief line. When it is de-energized, the spring pushes on the magnetic core and the disc is open, hence gas can flow to relief line. This device is usually integrated in burning system: when the system is de-energized, upstream safety shut off valves are closed, while vent valve is open, so that fuel gas inside pipe can be discharged in a safe area. In case of leakages of shut off valves, gas goes to relief line in a safe condition.

When the system is powered, vent valve closes while the main shut off valves open, hence fuel can flow to burner.

Fig. 1 shows a scheme of VMRNA valve.

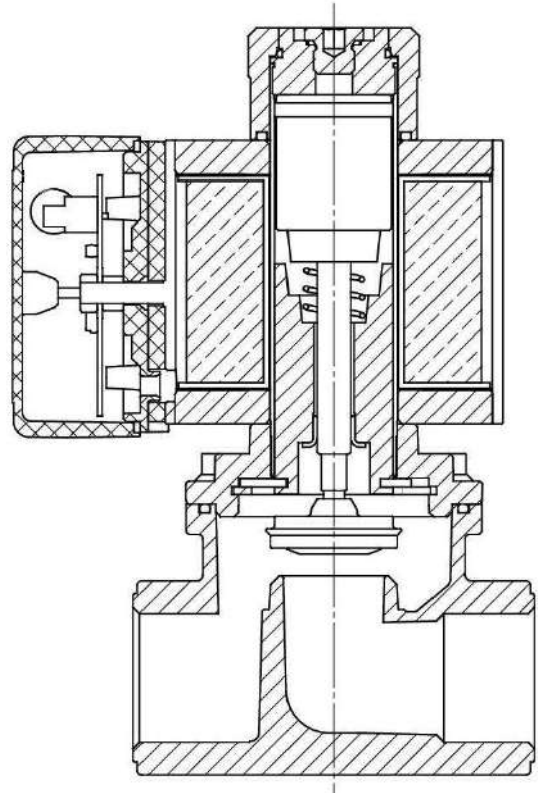

Fig. 1

This kind of valve is usually installed as safety device in gas trains, for industrial applications and gas firing systems. Fig. 2 shows an example of installation, in combination with other Elektrogas devices.

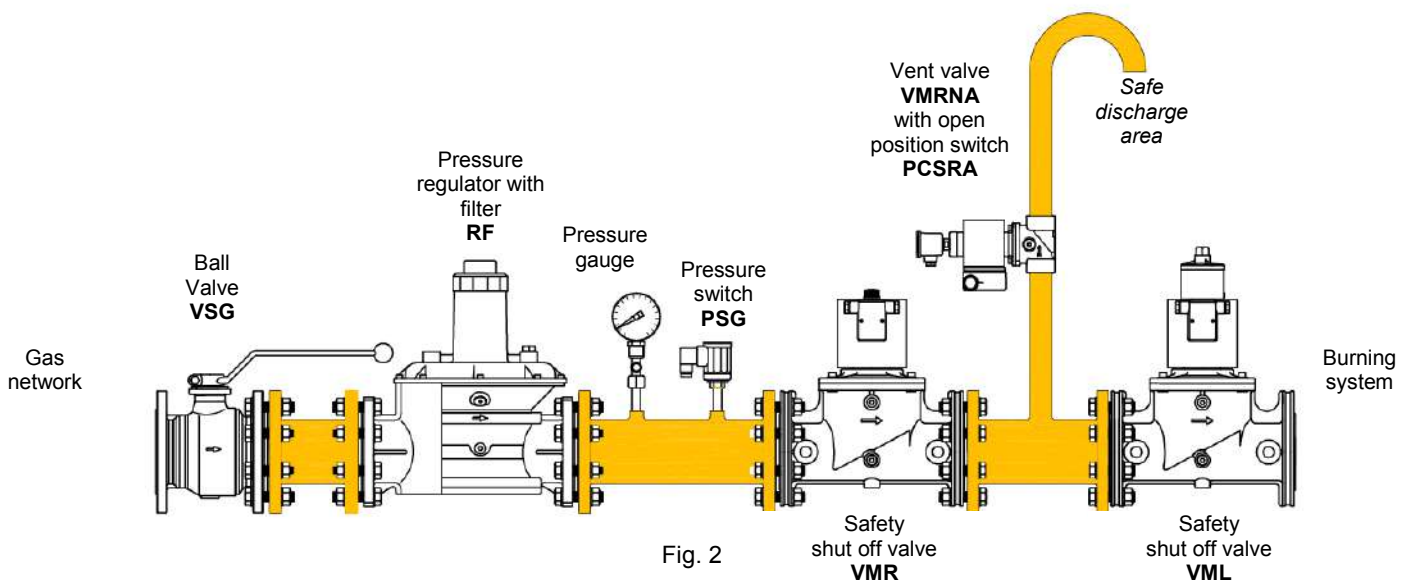

Fig. 2



WARNING

Location and mode of installation must be in compliance with local rules in force.

Technical specifications

Tab. 1

Connections	Internal threaded ISO 7-1 Rp3/4 - Rp1½ or ANSI-ASME B1.20 3/4"NPT – 1½"NPT (special ver.)	
Voltage	230 VAC 50/60 Hz 110 VAC 50/60 Hz	24V AC/DC
Max. operating pressure	500mbar (7psig) or 6bar (90psig) - only ¾"-1"	200mbar (3psig) or 2bar (30psig) – only ¾"-1"
Voltage tolerance	-15% to +10%	
Power consumption	35W	
Ambient temperature	-15°C / +60°C (+5°F to +140°F)	
Opening and closing time	< 1 second	
Protection class	IP54 (EN 60529) - optional IP65	
Cable gland and wire section	Terminal box: M20x1,5 - 2,5 mm ² max. or ISO plug (optional): PG9 - 1,5 mm ² max.	
Materials in contact with gas	Aluminum alloy, Brass, Stainless steel, Plated steel, Anaerobic adhesive, Nitrile rubber (NBR), Fluoro elastomer (FPM), Polytetrafluoroethylene (PTFE)	

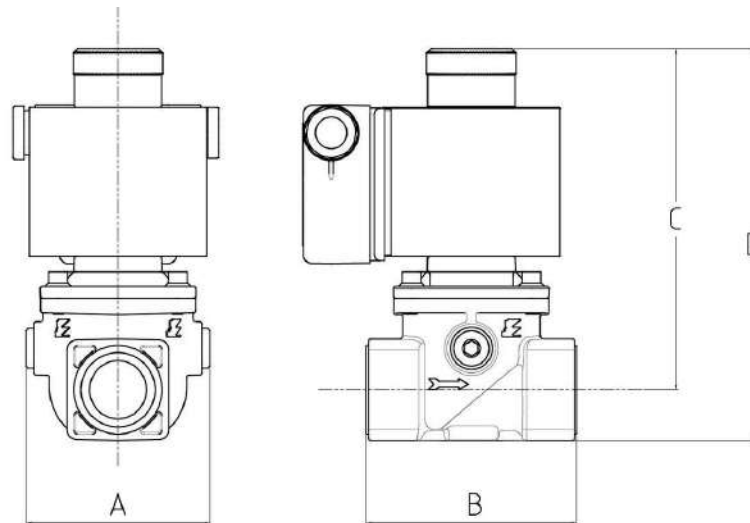

Fig. 3

Tab. 2

Model	Connection	A (mm)	B (mm)	C (mm)	D (mm)	Weight (Kg)
VMRNA2..	¾"	83	95	151	174	2,9
VMRNA3..	1"	83	95	151	174	2,9
VMRNA35..	1¼"	115	152	178	211	4,0
VMRNA4..	1½"	115	152	178	211	4,0

Gas flow chart

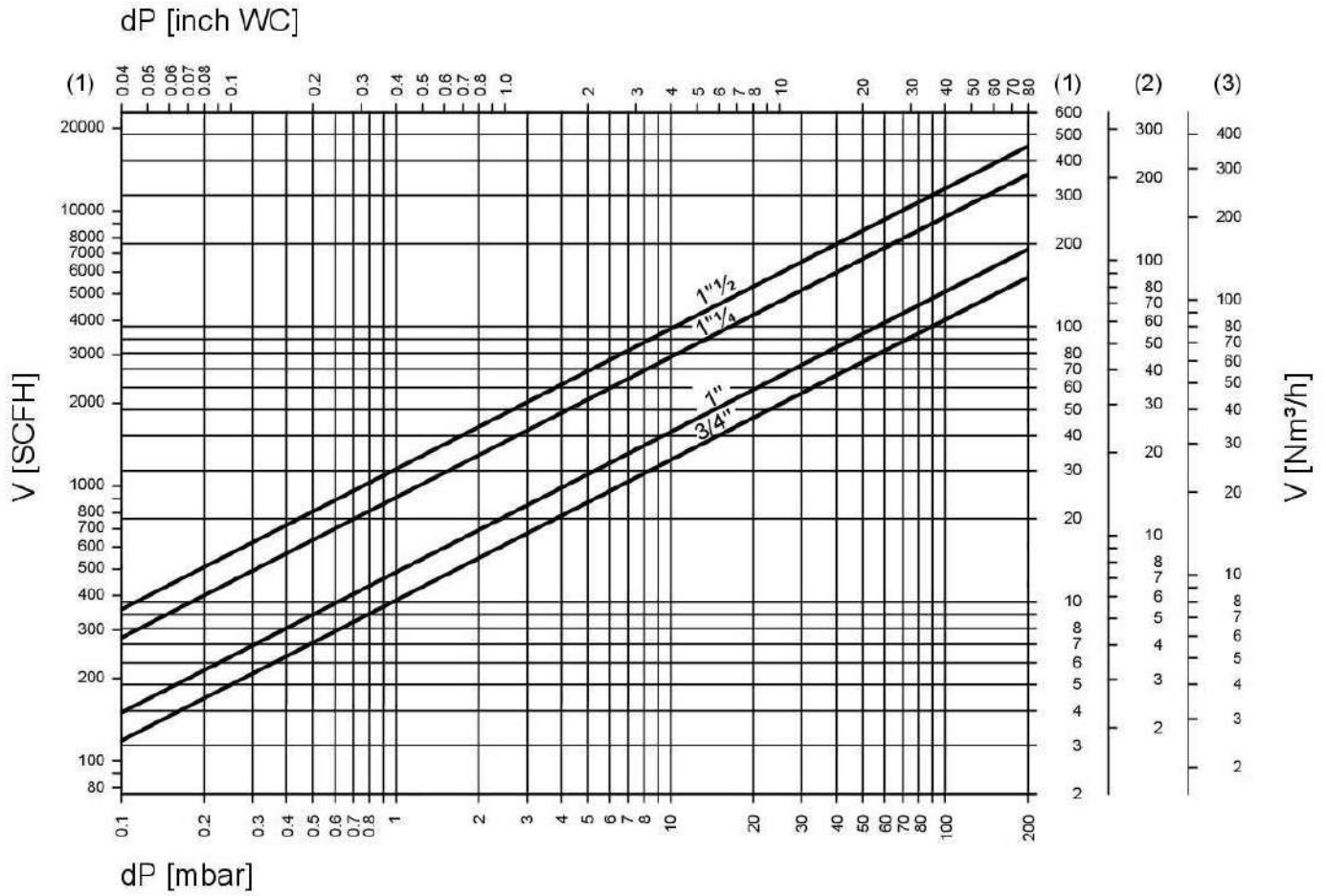

Fig. 4

**Formula of conversion
from air to other gases**

$$V_{GAS} = k \cdot V_{AIR}$$

Tab. 3

Gas type	Specific gravity ρ [Kg/m³]	$k = \sqrt{\frac{1.25}{\rho_{GAS}}}$
1 - Natural gas	0,80	1,25
2 - LPG	2,08	0,77
3 - Air	1,25	1,00

Standard conditions: 15°C, 1013 mbar, dry

When the flow read on the diagram is referred to operating pressure instead of standard conditions, the pressure drop Δp read on the diagram must be multiplied for the factor:

(1+ relative pressure in bar)

Ordering Information

Tab. 4

	VMRNA	2	-5	-
Valve type VMRNA				
Connections size				
2 = 3/4"				
3 = 1"				
35 = 1 1/4"				
4 = 1 1/2"				
M = integrated in VMM 1 1/4"-3" (*)				
Supply voltage and operating pressure				
-5 = 230V AC 500mbar				
-60 = 230V AC 6bar (only 3/4"-1")				
-5.B = 110V AC 500mbar				
-60.B = 110V AC 500mbar (only 3/4"-1")				
-2.C = 24V AC/DC 200mbar				
-20.C = 24V AC/DC 2 bar (only 3/4"-1")				
Special version				
N = NPT connection and 120V AC voltage				
J = version for bio gas				

Example: **VMRNA2-5.B** : valve 3/4", 110V AC, 500mbar

(*) Pictures below show a VMM valve assembled with an integrated VMRNA element:



Fig. 5

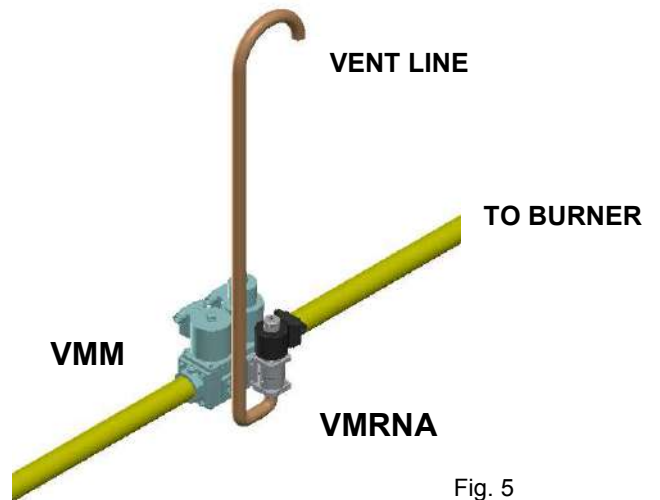

Fig. 5

Special versions

VMRNA valve can be manufactured with NPT connection (ANSI-ASME B1.20) and 120V AC coil.

Vent valve can be supplied in J version suitable for aggressive gases (i.e. biogas). This version is free of nonferrous metals and equipped with special seals.

Options

- Enclosure class can be increased up to IP65. The valves will be provided with a sealed terminal box and cable set.
- Valves can be provided with a special execution for use in Zones 2 and 22, according to 2014/34/EU Directive (ATEX):

category	II 3 G,D
protection mode	Ex nA IIA T4 Gc X Ex tc IIIB T135°C Dc X or Ex tc IIIC T135°C Dc X (IP65)

- Valves can be provided with transparent cover and LED which lights up when electrical power is supplied.
- Valves can be provided with electrical connection made by a standard plug ISO 4400.

Standards and approvals

The valves are designed and manufactured according to European standard EN 16304.

The following standards/technical specifications have been fulfilled:

- Electromagnetic Compatibility (2014/30/UE)
- Low Voltage Directive (2014/35/UE)
- Rohs II (2011/65/UE)
- Pressure Equipment Directive (2014/68/UE) – art. 4.3 (2bar or 6bar models)
- ATEX (2014/34/UE) when shown upon the product.

Quality Management System of manufacturer is certified according to UNI EN ISO 9001 and the monitoring is carried out by the notified body:

Kiwa Cermet Italia Spa

Reg.-n° 11989-A



Elektrogas® is a brand name of

ELETTROMECCANICA DELTA S.p.A. - Via Trieste, 132 - 31030 Arcade (TV) - Italy - Tel +39 0422 874068

www.delta-elektrogas.com

info@delta-elektrogas.com

ELETTROMECCANICA DELTA S.p.A. reserves the right to update or make any technical changes without prior notice.

Copyright © 2018. All rights reserved.