

AT 9/9

Dimensions in mm, subject to change.

AT S-9/9 7.9 kg

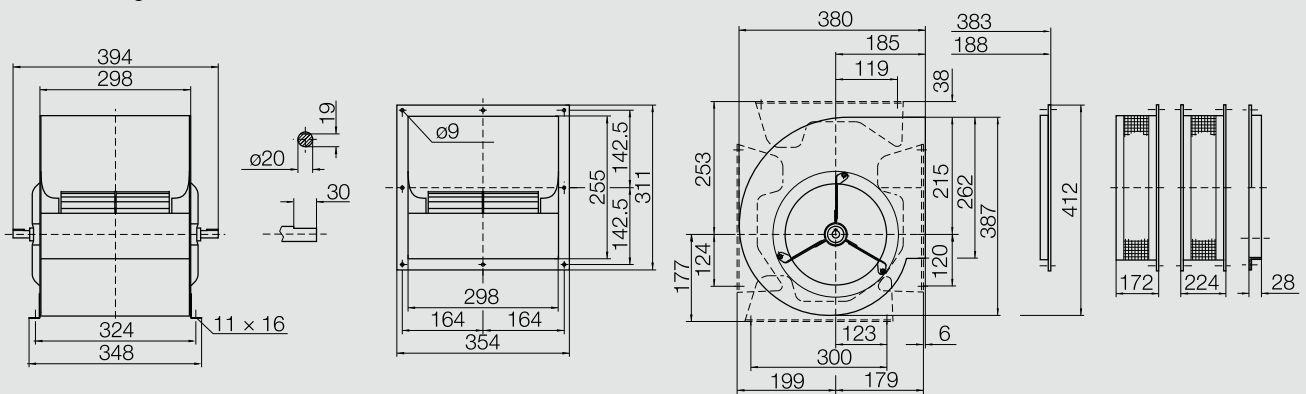

AT SC-9/9 9.5 kg

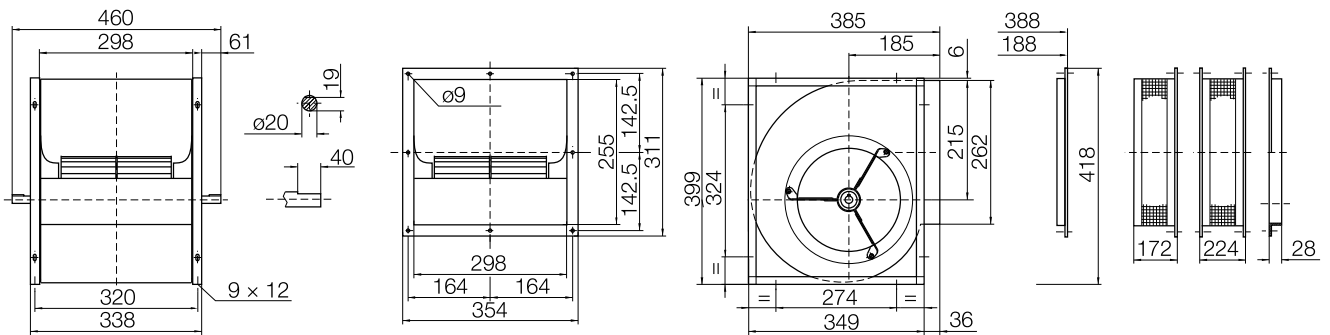

AT AR-9/9 9.5 kg

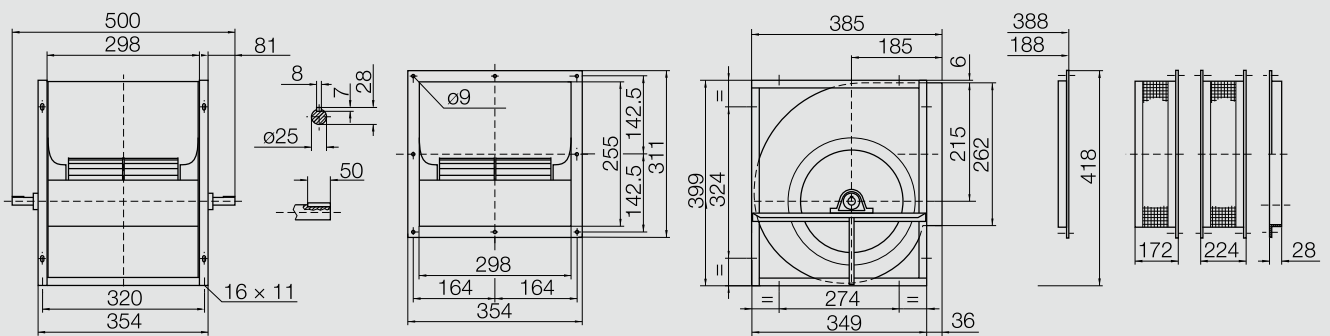

AT 9/9

Performance certified is for installation type B - free inlet, ducted outlet.
 Power rating (kW) does not include transmission losses.
 Performance ratings do not include the effects of appurtenances (accessories).

Technical Data

Impeller Data

Impeller diameter	D_r	242 mm
Number of blades	z	43
Moment of Inertia	J	0.034 kgm ²

Impeller Data

Impeller weight	m	2.9 kg
Density of media	ρ_1	1.2 kg/m ³
Tolerance class (DIN 24166)		2

Performance Curves

Please note coloured area!

- all types suitable
- AT AR only
- do not use in this area



Nicotra Gebhardt S.p.A certifies that the fan shown herein is licensed to bear the AMCA Seal. The ratings shown are based on tests and procedures performed in accordance with AMCA Publication 211 and comply with the requirements of the AMCA Certified Ratings Program. The AMCA Certified Ratings Seal applies to air performance ratings only.

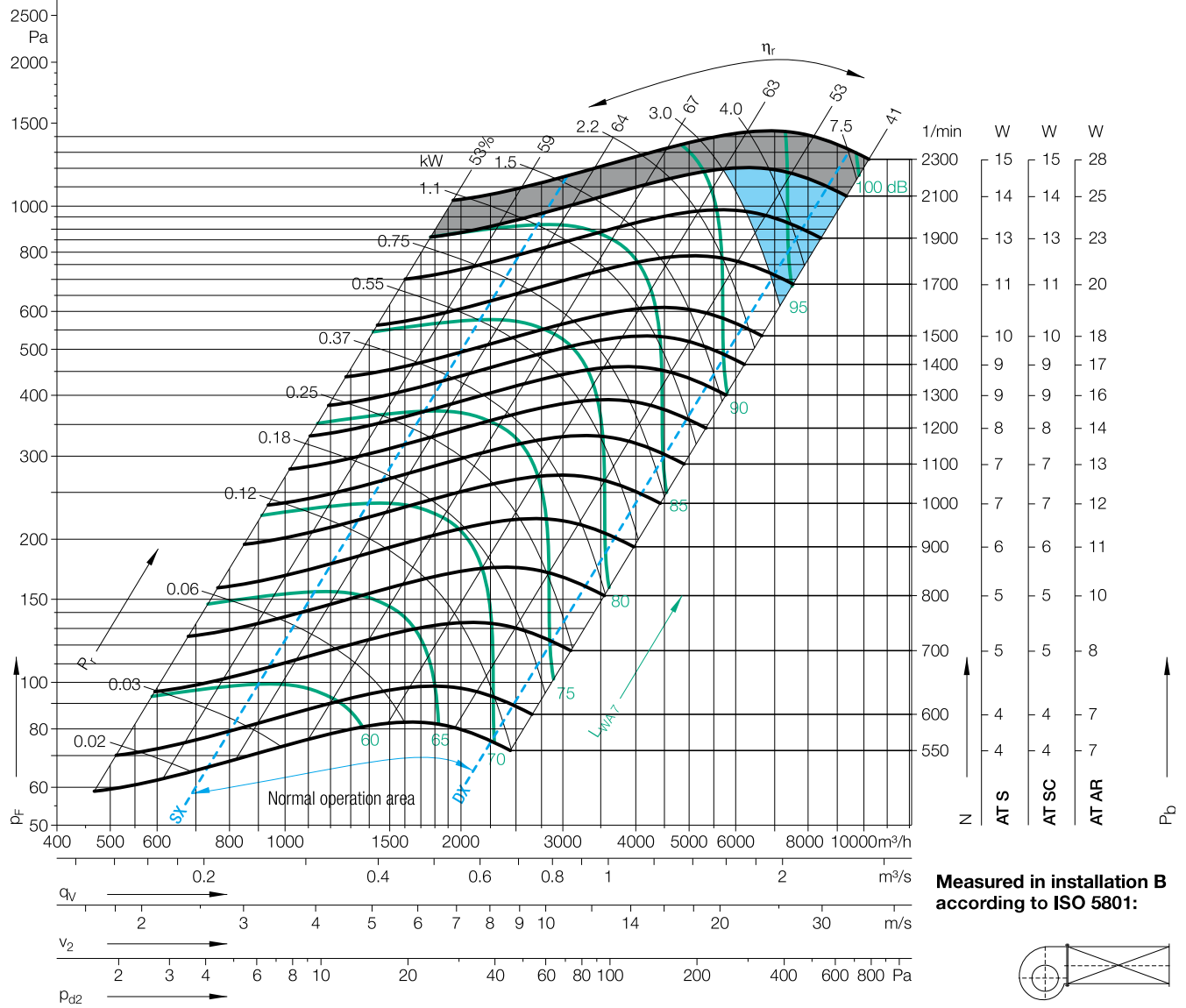

Measured in installation B according to ISO 5801:

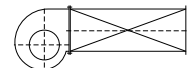

$\Delta L_{Wrel4}(A)$

Relative sound power level for inlet side L_{Wrel4} at octave centre frequencies f_c

Relative sound power level for discharge side L_{Wrel4} at octave centre frequencies f_c

Duty point	Speed 1/min	dB
SX	1900	2
SX	1200	2
SX	700	2
$Q_{V,opt}$	1900	2
$Q_{V,opt}$	1200	1
$Q_{V,opt}$	700	1
DX	1900	2
DX	1200	2
DX	700	2

	63	125	250	500	1000	2000	4000	8000	Hz
0	-5	2	-8	-7	-6	-10	-16		dB
-4	4	-5	-5	-5	-6	-12	-20		dB
4	0	-4	-3	-4	-8	-16	-23		dB
-5	-8	2	-7	-7	-6	-9	-13		dB
-8	3	-4	-6	-5	-6	-10	-17		dB
2	0	-5	-4	-4	-7	-14	-21		dB
-9	-12	-3	-12	-10	-6	-6	-7		dB
-13	-3	-10	-11	-7	-5	-7	-10		dB
-5	-6	-11	-7	-5	-6	-8	-14		dB

	63	125	250	500	1000	2000	4000	8000	Hz
9	1	6	-5	-4	-5	-8	-14		dB
3	8	-2	-3	-3	-5	-10	-18		dB
9	4	-1	-1	-2	-7	-14	-22		dB
3	-3	4	-5	-5	-6	-8	-12		dB
-2	6	-2	-4	-4	-5	-9	-16		dB
6	3	-2	-3	-3	-6	-12	-20		dB
-2	-8	1	-9	-6	-4	-4	-6		dB
-7	1	-8	-8	-4	-4	-5	-9		dB
-1	-4	-8	-4	-3	-4	-7	-14		dB