

Thermic & Co code 953099

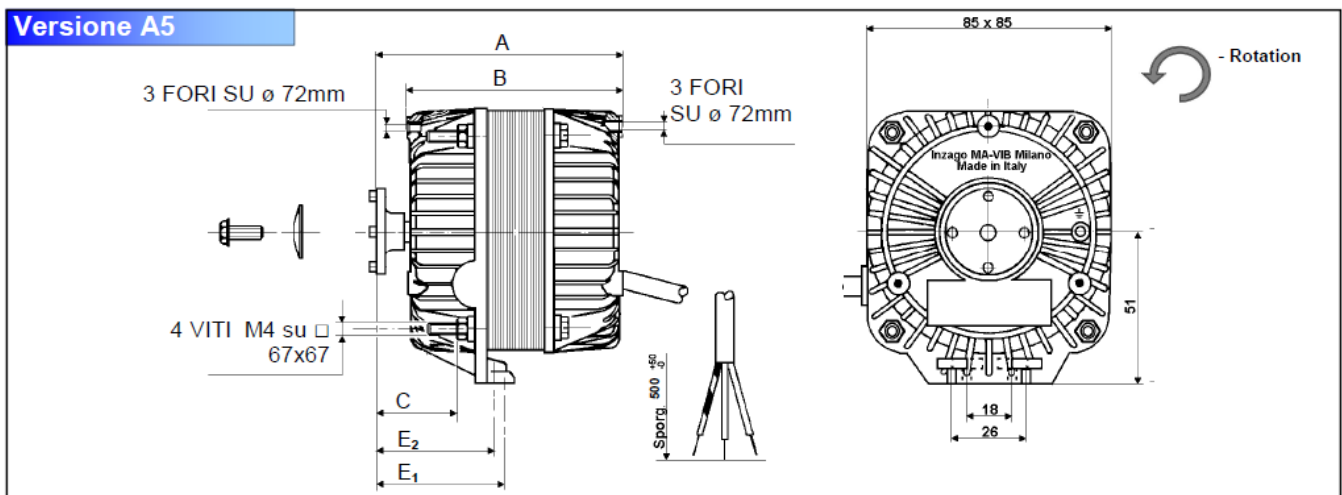

EF16Y0.A5 : A=91 – B=73 – C=37 - E1=53 – E2=47

Vitesse rotation 1300 t/min, protection thermique.

Alimentation 230 V 50/60 Hz, marquage CE, conforme à IEC/EN60335-1

Hélices maximales : 230 mm 31° , 254 mm 27° et 300 mm 16°

